

VEJLBY

3690380 / 83056001

3690386 / 83057001

3690388 / 3690391

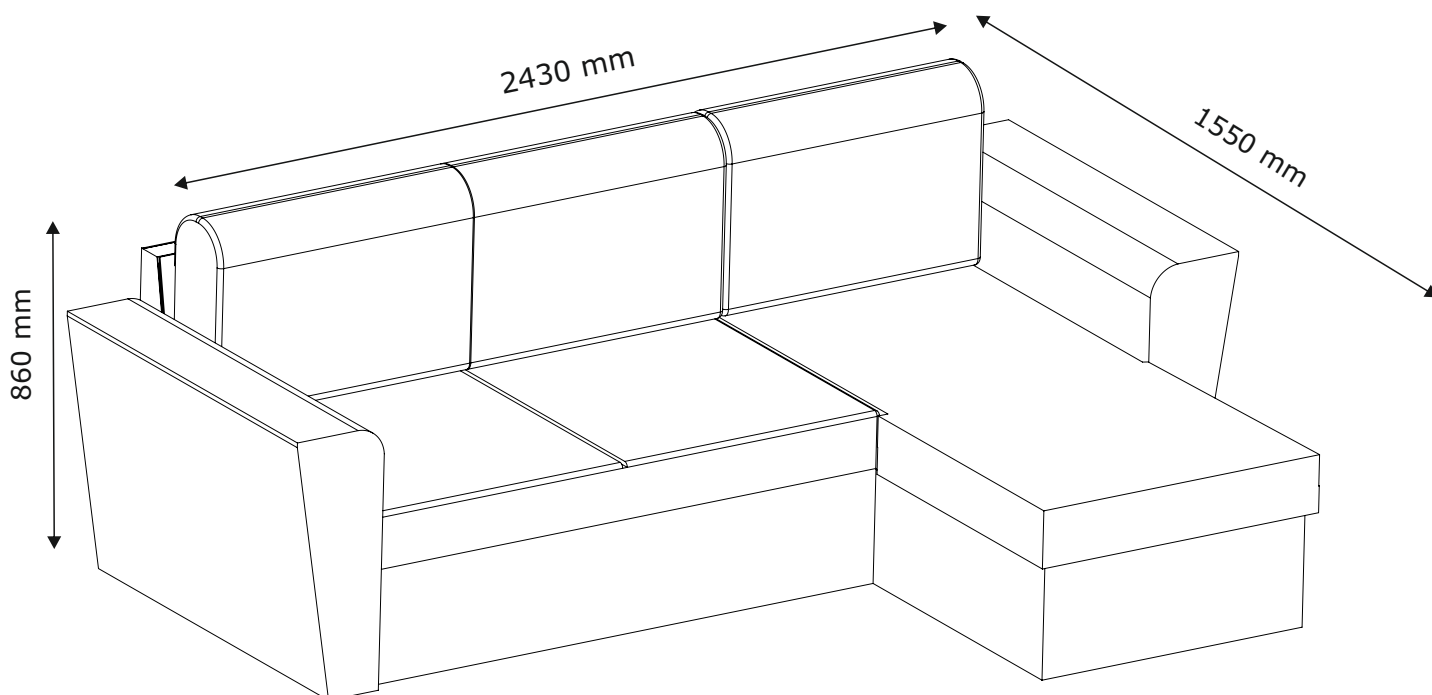

24.07.2025 - Rev. 4

1/35

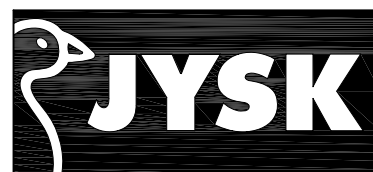

JYSK.com

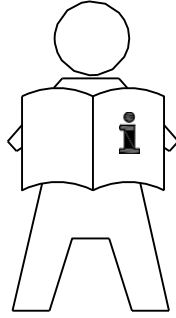
**GB IMPORTANT INFORMATION!**

Please read the entire manual carefully before starting to assemble and/or using this product. Follow the manual thoroughly and keep it for further reference.

DK VIGTIG INFORMATION!

Læs hele manualen grundigt igennem før samling og/eller brug af dette produkt. Følg manualen nøje, og opbevar den til senere brug.

DE WICHTIGE INFORMATIONEN!

Bitte lesen Sie die gesamte Anleitung sorgfältig durch, bevor Sie mit der Montage und/oder Verwendung dieses Produkts beginnen. Befolgen Sie die Anleitung genau und bewahren Sie diese für den späteren Gebrauch auf.

NO VIKTIG INFORMASJON!

Les hele bruksanvisningen nøye før du begynner å montere og/eller bruke dette produktet. Følg bruksanvisningen nøye, og ta vare på den for fremtidig bruk.

SE VIKTIG INFORMATION!

Läs bruksanvisningen i sin helhet innan du börjar att montera och/eller använda produkten. Följ bruksanvisningen noggrant och spara den för framtida referens.

FI TÄRKEITÄ TIETOJA

Lue käyttöohjeet kokonaan ennen tämän tuotteen kokoamista ja/tai käyttöä. Noudata käyttöohjeita tarkasti ja säilytä ne myöhempää tarvetta varten.

PL WAŻNE INFORMACJE.

Przed użyciem produktu należy dokładnie zapoznać się ze wskazówkami bezpieczeństwa. Należy zapoznać się z instrukcją obsługi i zachować ją do użytku w przyszłości.

CZ DŮLEŽITÉ INFORMACE!

Před sestavením nebo použitím výrobku si pečlivě přečtěte celý návod. Dodržujte důsledně uvedené pokyny a návod uschovejte, aby byl k dispozici v případě potřeby.

HU FONTOS INFORMÁCIÓ

A termék összeszerelésének vagy használatának megkezdése előtt figyelmesen olvassa el a teljes útmutatót. Őrizze meg az útmutatót, és gondosan tartsa be a benne foglaltakat.

NL BELANGRIJKE INFORMATIE!

Lees de volledige handleiding zorgvuldig door voordat u dit product monteert en/of gebruikt. Volg de handleiding zorgvuldig en bewaar deze voor toekomstig gebruik.

SK DŮLEŽITÉ INFORMÁCIE!

Predtým ako začnete s montážou a/alebo používaním tohto produktu si pozorne prečítajte celý návod. Návod dôsledne dodržiavajte a ponechajte si ho pre použitie v budúcnosti.

FR INFORMATIONS IMPORTANTES

Veillez lire attentivement l'ensemble du manuel avant de commencer à monter et/ou utiliser ce produit. Suivez rigoureusement le manuel et conservez-le pour toute consultation ultérieure.

SI POMEMBNE INFORMACIJE!

Pred montažo/porabo izdelka pozorno preberite ta navodila za uporabo. Upošteвайте navodila in jih shranite, saj jih boste morda še potrebovali.

HR VAŽNE OBAVIJESTI!

Molimo Vas pažljivo pročitajte upute za uporabu prije sastavljanja i/ili korištenja ovog proizvoda. Strogo se pridržavajte uputa i sačuvajte ih za buduće potrebe.

IT INFORMAZIONI IMPORTANTI!

Si prega di leggere attentamente l'intero manuale prima di cominciare a montare e/o a utilizzare questo prodotto. Seguire rigorosamente le istruzioni di questo manuale e conservarlo per una successiva consultazione.

ES INFORMACIÓN IMPORTANTE

Leer con atención todo el manual antes de comenzar a ensamblar/usar este producto. Seguir a conciencia las instrucciones del manual y conservarlo para futuras consultas.

BA VAŽNE INFORMACIJE!

Prije sklapanja i/ili korištenja ovog proizvoda, pažljivo pročitajte cijeli priručnik. Pažljivo se pridržavajte uputstava u priručniku i sačuvajte ga za buduću upotrebu.

RS VAŽNE INFORMACIJE!

Pažljivo pročitajte kompletan priručnik pre nego što počnete da sklapate i/ili koristite ovaj proizvod. Detaljno sledite priručnik i sačuvajte ga za kasniju upotrebu.

UA ВАЖЛИВА ІНФОРМАЦІЯ.

Уважно прочитайте весь посібник, перш ніж збирати та/чи використовувати цей продукт. Виконайте всі інструкції цього посібника та збережіть його для подальшого використання.

RO INFORMAȚII IMPORTANTE

Citiți cu atenție întregul manual înainte de a începe să montați și/sau să utilizați acest produs. Urmați îndeaproape instrucțiunile din manual și păstrați-l pentru consultare ulterioară.

BG ВАЖНА ИНФОРМАЦИЯ!

Моля, прочетете цялото ръководство внимателно, преди да започнете да сглобявате и/или използвате този продукт. Следвайте стриктно ръководството и го пазете за бъдещи справки.

GR ΣΗΜΑΝΤΙΚΕΣ ΠΛΗΡΟΦΟΡΙΕΣ!

Διαβάστε προσεκτικά ολόκληρο το εγχειρίδιο πριν από τη συναρμολόγηση ή/και τη χρήση του προϊόντος. Ακολουθήστε προσεκτικά τις οδηγίες του εγχειριδίου και κρατήστε τις για μελλοντική αναφορά.

PT INFORMAÇÕES IMPORTANTES!

Queira ler este manual inteiro e com atenção antes de começar a montar e/ou usar este produto. Siga as instruções de forma cuidadosa e guarde-as para referência futura.

RU ВАЖНАЯ ИНФОРМАЦИЯ!

Внимательно и полностью прочитайте это руководство, прежде чем приступить к сборке или использованию этого изделия. Следуйте всем инструкциям этого руководства и сохраните его на будущее для справки.

TR ÖNEMLİ BİLGİLER!

Bu ürünün montajını yapmaya başlamadan ve/veya ürünü kullanmadan önce lütfen kılavuzun tamamını dikkatlice okuyun. Kılavuzu adım adım izleyin ve daha sonra başvurmak üzere saklayın.

CN 重要信息!

组装和/或使用本产品之前请通读该手册。请严格遵循手册说明，保留手册供日后参考。

AR كودم تاداشر!

جئتملا اهد مادختسا و/و عيمجت يف ايلدا لبق تيناعب هلمكاب ليلدا عئارق جريهيب ففتحاو لامكاب ليلدا يف درو ام عئو عجرال لبقتملا يف هيل.

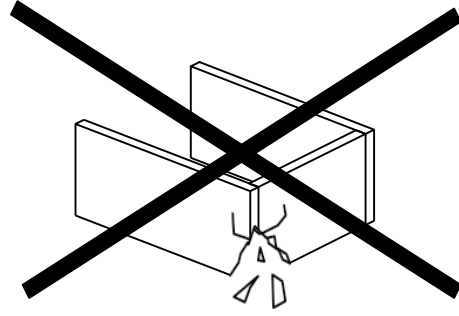
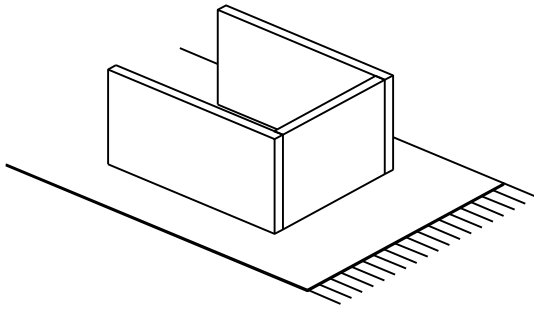

GB WARNING TO AVOID SCRATCHES!

In order to avoid scratching this furniture should be assembled on a soft layer - could be a rug.

DK ADVARSEL FOR AT FORHINDRE RIDSER!

For at forhindre ridser skal dette møbel samles på et blødt underlag, f.eks. et tæppe.

DE HINWEIS ZUR VERMEIDUNG VON KRATZERN

Um Kratzer zu vermeiden, sollte dieses Möbelstück auf einer weichen Unterlage montiert werden (z. B. Teppich).

NO ADVARSEL FOR Å UNNGÅ RIPER!

For å unngå ripper må møbelet monteres på et mykt underlag, for eksempel et teppe.

SE VARNING OM HUR DU UNDVIKER REPOR!

För att undvika repor ska denna möbel monteras på ett mjukt underlag, exempelvis en matta.

FI VARO NAARMUJA!

Varo naarmuja ja kokoa tämä kaluste pehmeällä alustalla, esimerkiksi maton päällä.

PL OSTRZEŻENIE WS. USZKODZEŃ

Aby uniknąć rys, ten mebel powinien być montowany, składany na miękkim podłożu, np. dywanie.

CZ VAROVÁNÍ TÝKAJÍCÍ SE POŠKRÁBÁNÍ!

Aby nedošlo k poškrábání, sestavujte nábytek na měkkém podkladu – např. na koberci.

HU KARCOLÁSOK MEGELŐZÉSE – FIGYELEM!

A karcolások megelőzése érdekében a bútort puha felületen, például szőnyegen kell összeszerelni.

NL WAARSCHUWING OM KRASSEN TE VERMIJDEN!

Om te voorkomen dat dit meubel krassen vertoont, moet het gemonteerd worden op een zachte ondergrond - zoals een tapijt

SK VÝSTRAHA TÝKAJÚCA SA PREDCHÁDZANIA ŠKRABANCOM!

Aby sa predišlo škrabancom, tento nábytok by sa mal montovať na mäkkom podklade, napríklad na koberci.

FR AVERTISSEMENT POUR ÉVITER LES RAYURES

Afin d'éviter les rayures, ce meuble doit être monté sur une surface souple (un tapis, par exemple).

SI KAKO PREPREČITI PRASKE!

Da bi se izognili praskam na pohištvu, pohištvo sestavite na mehki podlagi, npr. na preprogi

HR UPOZORENJE O IZBJEGAVANJU OGREBOTINA!

Kako bi se izbjegle ogrebotine, ovaj proizvod potrebno je sastavljati na mekanoj površini - primjerice, na tepihu.

IT AVVERTENZA PER EVITARE I GRAFFI!

Per evitare i graffi, si raccomanda di montare questo mobile su una superficie morbida (come ad es. un tappeto).

ES ADVERTENCIA PARA EVITAR RAYADURAS

Para no rayar este mueble, es aconsejable ensamblarlo sobre una superficie suave (posiblemente una alfombra).

BA UPOZORENJE ZA SPRJEČAVANJE NASTANKA OGREBOTINA!

Da bi se izbjegle ogrebotine na ovom nameštaju, poželjno ga je sastaviti na mekoj podlozi - na primjer, tepihu.

RS UPOZORENJE ZA IZBJEGAVANJE OGREBOTINA!

Da biste izbegli ogrebotine, ovaj nameštaj treba da sastavljate na mekoj podlozi - može prostirka.

UA ПОПЕРЕДЖЕННЯ ЩОДО ПОДРЯПИН.

Щоб уникнути подряпин, ці меблі слід збирати на м'якій поверхні, наприклад, на килимі.

RO ATENȚIONARE PENTRU EVITAREA ZGĂRIERII!

Pentru evitarea zgârierii, această piesă de mobilier trebuie să fie montată pe o suprafață moale, de exemplu, pe un covor.

BG ПРЕДУПРЕЖДЕНИЕ ЗА ИЗБЯГВАНЕ НА ДРАСКОТИНИ!

За да избегнете надраскване, тази мебел трябва да бъде сглобена на мека повърхност – например килим.

GR ΠΡΟΕΙΔΟΠΟΙΗΣΗ ΓΙΑ ΤΗΝ ΑΠΟΦΥΓΗ ΓΡΑΤΣΟΥΝΙΩΝ!

Για την αποφυγή γρατσουνιών, το έπιπλο θα πρέπει να συναρμολογηθεί σε μαλακή επιφάνεια, όπως για παράδειγμα πάνω σε ένα χαλί.

PT AVISO PARA EVITAR RISCOS

Para evitar riscos, este móvel deve ser montado numa superfície macia (por exemplo, tapete).

RU ПРЕДУПРЕЖДЕНИЕ ОТНОСИТЕЛЬНО ЦАРАПИН!

Во избежание нанесения царапин, сборку этой мебели необходимо выполнять на мягкой поверхности, например на ковре.

TR ÇİZİLMELERİ ÖNLEMENE YÖNELİK UYARI!

Bu mobilyanın çizilmesini engellemek için montajını halı gibi yumuşak bir yüzeyin üzerinde yapın.

CN 防刮警告!

为了避免刮伤家具，应在地毯等软面上进行组装。

AR **ينجتن ريدحت شويخلا!**

معتاد قلم طبع هذه نائث العتقط عيمجت يغيني شويخ الينجتن ريدحت شويخ عتقط.

GB WARNING FOR SEATING FURNITURE!

This seating furniture is tested for domestic use. Tested for 110 kg. per seat.

DK ADVARSEL VEDRØRENDE SIDDEMØBLER!

Dette sidde møbel er testet til brug i private hjem. Testet for 110 kg. pr. siddeplads.

DE WARNUNG FÜR SITZMÖBEL!

Dieses Sitzmöbel ist für den häuslichen Gebrauch getestet. Getestet für 110 kg je Sitz.

NO ADVARSEL FOR SITTEMØBEL!

Dette sittemøbelet er testet for hjemm bruk. Testet for 110 kg per sitteplass.

SE VARNING GÄLLANDE SITTMÖBLER!

Den här sittmöbeln är testad för hemmabruk. Testad för 110 kg per sits.

FI ISTUINHUONEKALUA KOSKEVA VAROITUS

Tämä istuinhuonekalu on testattu kotikäyttöä varten. Testattu 110 kg:lle istuinta kohden.

PL OSTRZEŻENIE DOTYCZĄCE SIEDZISKA!

To siedzisko zostało przetestowane pod kątem użytku domowego. Przetestowane obciążenie: 110 kg/siedzisko.

CZ VAROVÁNÍ PRO SEDACÍ NÁBYTEK.

Tento sedací nábytek je testován na domácí použití. Testováno na 110 kg na sedák.

HU ÜLŐBÜTORRAL KAPCSOLATOS FIGYELMEZTETÉS

Ezt az ülóbütört háztartási használatra vizsgálták be. A vizsgálati terhelés ülésenként 110 kg volt.

NL WAARSCHUWING VOOR ZITMEUBILAIR!

Dit zitmeubel is getest voor huishoudelijk gebruik. Getest voor 110 kg. per stoel.

SK VÝSTRAHA PRE SEDACÍ NÁBYTOK!

Tento sedací nábytok je testovaný na použitie v domácnosti. Testovaný na hmotnosť 110 kg na sedadlo.

FR AVERTISSEMENT POUR LE MOBILIER D'ASSISE !

Ce mobilier d'assise a été testé pour un usage domestique. Testé pour un poids de 110 kilos par assise.

SI OPOZORILO ZA SEDEŽNO POHIŠTVO!

To sedežno pohištvo je preiskušeno za domačo uporabo. Preskušeno za 110 kg/sedež.

HR UPOZORENJE O NAMJEŠTAJU ZA SJEDENJE!

Ovaj namještaj za sjedenje testiran je za kućnu uporabu. Testiran je za težinu od 110 kg po sjedalu.

IT AVVERTENZA PER SEDUTE D'ARREDO!

Queste sedute d'arredo sono testate per un uso domestico. Testate per 110 kg per seduta.

ES ¡ADVERTENCIA PARA ASIENTOS!

Este asiento se ha probado para uso doméstico. Probado para 110 kg por asiento.

BA UPOZORENJE ZA NAMJEŠTAJ ZA SJEDENJE!

Ovaj namještaj za sjedenje je testiran za kućnu upotrebu. Testirano za 110 kg po sjedištu.

RS UPOZORENJE VEZANO ZA NAMEŠTAJ ZA SEDENJE!

Ovaj nameštaj za sedenje je testiran za kućnu upotrebu. Testirano na 110 kg po mestu za sedenje.

UA ПОПЕРЕДЖЕННЯ ЩОДО ВИКОРИСТАННЯ МЕБЛІВ ДЛЯ СІДІННЯ.

Ці меблі для сидіння призначено для використання в домашніх умовах. Максимальне навантаження 110 кг на одне сидіння.

RO ATENȚIONARE PRIVIND MOBILIERUL PENTRU ȘEZUT!

Acest mobilier pentru șezut este testat pentru uz casnic. Testat pentru 110 kg per piesă de mobilier pentru șezut.

BG ПРЕДУПРЕЖДЕНИЕ ЗА МЕБЕЛИ ЗА СЯДАНЕ!

Тази мебел за сядане е преминала изпитания за домашна употреба. Преминала изпитания за тегло 110 кг на седалка.

GR ΠΡΟΕΙΔΟΠΟΙΗΣΗ ΓΙΑ ΤΑ ΚΑΘΙΣΜΑΤΑ!

Αυτά τα καθίσματα έχουν δοκιμαστεί για οικιακή χρήση. Δοκιμασμένα για 110 κιλά ανά θέση.

PT AVISO PARA CADEIRAS!

Estas cadeiras foram testadas apenas para uso doméstico. Testadas para 110 kg por cadeira.

RU ПРЕДУПРЕЖДЕНИЕ ДЛЯ МЯГКОЙ МЕБЕЛИ!

Эта мягкая мебель прошла проверку на пригодность для применения в домашних условиях. Максимально допустимый вес — 110 кг. на одно посадочное место

TR BÜRO SANDALYELERİNE YÖNELİK UYARI!

Bu masa sandalyesi evde kullanım için test edilmiştir. 110 kg için test edilmiştir.

CN 座椅警告信息!

该款座椅经过测试可在室内使用。测试重量为每个椅子 110 kg。

AR سولجیل صصخلمما ئائالا انشب ریختا!
امت العتقظ رایتخ للصصصمخ الیهذ ٹک نزو رایتخ امت. یزلتم المخداتمال لسوجل 110نحوا الدعقم للمعک.

GB IMPORTANT!

It is important that any product which is assembled using any kind of screw is re-tightened 2 weeks after assembly, and once every 3 months - in order to assure stability through-out the lifespan of the product.

DK VIGTIGT!

Det er vigtigt, at alle produkter, der samles med alle former for skruer, efterspændes to uger efter samling samt hver tredje måned for at sikre, at produktet er stabilt i hele dets levetid.

DE WICHTIG!

Es ist wichtig, bei jedem mit Schrauben montierten Produkt diese 2 Wochen nach dem Zusammenbau sowie einmal alle 3 Monate wieder anzuziehen, um die Stabilität des Produkts über die gesamte Lebensdauer hinweg zu gewährleisten.

NO VIKTIG!

Det er viktig at alle produkter som monteres med skruer blir etterstrammet 2 uker etter montering, og hver 3. måned for å sikre stabiliteten gjennom hele produktets levetid

SE VIKTIGT!

För alla produkter som monteras med skruv är det viktigt att dessa efterdras två veckor efter monteringen och därefter en gång var tredje månad. Detta för att säkerställa att produkten håller sig stabil under hela sin livslängd.

FI TÄRKEÄÄ!

On tärkeää, että kaikki ruuvien avulla koottavat tuotteet kiristetään uudelleen 2 viikkoa kokoamisen jälkeen ja aina 3 kuukauden välein, jotta tuote pysyy vakaana koko käyttöikänsä ajan.

PL WAŻNE!

Ważne jest, żeby każdy ze skręcanych produktów został ponownie dokręcony w ciągu 2 tygodni od montażu, a następnie sprawdzić co 3 miesiące czy śruby są dokręcone — w celu zapewnienia stabilności przez czas użytkowania produktu.

CZ DŮLEŽITÉ!

U každého výrobku, který se sestavuje pomocí jakýchkoli šroubků, je důležité dotáhnout šroubky 2 týdny po sestavení a potom každé 3 měsíce, aby byla zajištěna stabilita po celou dobu životnosti výrobku.

HU FONTOS!

Minden terméknél fontos, hogy bármilyen fajta csavarral is történi az összeszerelése, utána 2 héttel, majd 3 havi rendszerességgel szükséges a csavarok utánhúzóása. Ezzel a termék teljes élettartamán keresztül biztosítható a stabilitása.

NL BELANGRIJK!

Het is belangrijk om elk product dat met om het even welk soort schroef wordt gemonteerd, twee weken na montage en om de drie maanden, opnieuw wordt vastgeschroefd, om de stabiliteit van het product tijdens de hele levensduur te verzekeren.

SK DŮLEŽITÉ!

Je dôležité, aby sa na akomkoľvek produkte, montovanom pomocou akýchkoľvek skrutiek, skrutky dotiahli po dvoch týždňoch od montáže, a jedenkrát v priebehu každých 3 mesiacov – tak sa zaručí stabilita počas celej životnosti produktu.

FR IMPORTANT

Il est important que tout produit monté à l'aide de vis soit resserré 2 semaines après son montage, puis tous les 3 mois, afin de garantir sa stabilité durant tout son cycle de vie.

SI POMEMBNO!

Vsak izdelek, ki ga sestavite z uporabo kakršnihkoli vijakov morate 2 tedna po sestavitvi ponovno pregledati in vijake po potrebi priviti. To ponovite vsake 3 mesece, da bi zagotovili stabilnost izdelka skozi njegovo celotno življenjsko dobo.

HR VAŽNO!

Važno je da se svi tipovi vijaka na bilo kojoj vrsti proizvoda koji se s pomoću njih sastavlja ponovno pritegnu 2 tjedna nakon sastavljanja te jednom svaka 3 mjeseca - kako bi se zajamčila stabilnost tijekom životnog vijeka proizvoda.

IT IMPORTANTE!

È importante in ogni prodotto montato con viti serrare ben strette le viti 2 settimane dopo il montaggio e poi ogni 3 mesi per garantire la sua stabilità durante tutta la durata del prodotto.

ES IMPORTANTE

En el caso de los productos ensamblados, es importante volver a apretar los tornillos 2 semanas después del montaje y después cada 3 meses, para así preservar la estabilidad durante toda la vida útil del producto.

BA VAŽNO!

Za sve proizvode sa vijčanim vezama, potrebno je izvršiti pritezanje 2 sedmice nakon sklapanja i svaka 3 mjeseca nakon toga, kako bi se osigurala stabilnost tokom cijelog životnog vijeka proizvoda.

RS VAŽNO!

Važno je da svaki proizvod koji je sklopljen korišćenjem bilo kakvih šrafova bude ponovo pričvršćen 2 nedelje nakon sklapanja i jednom svaka 3 meseca - kako bi se obezbedila stabilnost tokom celog veka trajanja proizvoda.

UA УВАГА.

Майте на увазі, якщо у процесі монтажу продукту використовуються гвинти будь-якого типу, їх треба повторно затягнути через 2 тижні після монтажу, а потім кожні 3 місяці. Це необхідно для того, щоб забезпечити надійне використання продукту протягом терміну його служби.

RO IMPORTANT!

Este important ca şuruburile de orice tip, cu ajutorul cărora au fost montate produsele, să fie strânse din nou la 2 săptămâni după montare şi, apoi, o dată la 3 luni, pentru a se asigura stabilitatea de-a lungul duratei de viaţă a produsului

BG ВАЖНО!

Важно е всеки продукт, който е сглобен с помощта на винтове, да бъде затегнат 2 седмици след сглобяването, и веднъж на всеки 3 месеца, за да се гарантира стабилност през цялото време на използване на продукта.

GR ΣΗΜΑΝΤΙΚΟ!

Για κάθε προϊόν που συναρμολογείται με βίδες είναι σημαντικό αυτές να ξανασφίγγονται 2 εβδομάδες μετά τη συναρμολόγηση και μία φορά κάθε 3 μήνες, για τη διασφάλιση της σταθερότητας σε όλη τη διάρκεια ζωής του προϊόντος.

PT AVISO IMPORTANTE!

É importante, em cada produto montado com parafusos, reapertar os mesmos 2 semanas após a montagem e uma vez a cada 3 meses para garantir a estabilidade do produto ao longo de toda a sua vida útil.

RU ВАЖНО!

В любом изделии, собранном с использованием винтов любого типа, необходимо через 2 недели после сборки и в дальнейшем каждые 3 месяца подтягивать винты, чтобы обеспечить прочность изделия в течение срока эксплуатации.

TR ÖNEMLİ!

Vida kullanılarak yapılan her türlü ürün montajı için montajdan 2 hafta sonra vidaların yeniden sıkıştırılması ve kullanım süresi boyunca ürün istikrarının sağlanması için de her 3 ayda bir vidaların sıkıştırılması önem arz eder.

CN 重要提示!

使用任何类型的螺钉组装的产品，必须在组装 2 周后重新拧紧，并且每 3 个月重新拧紧一次，以确保产品在整个使用期内结实稳固。

مهم! AR
كدا ماعكول النهر عن ي أمخاتسلب ماعججت مت جتتم ي أبطر بعراب أدعب لك كتحوا قرمو، عجمجت النهم زي عوبس 3 رهشأ - جتتم الرعم لوا طئناث النامضل

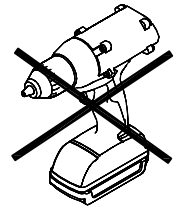
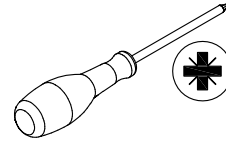

A x 4

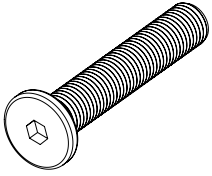

M8 x 75 mm

B x 9

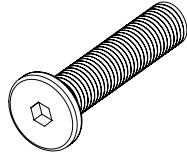

M8 x 50 mm

C x 4

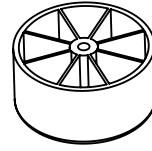

Ø50 x 35 mm

D x 2

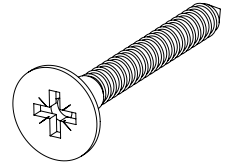

Ø5 x 30 mm

E x 2

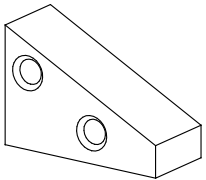

35 x 24 x 15 mm

F x 1

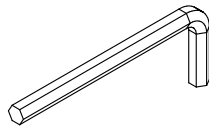

5 mm

G x 4

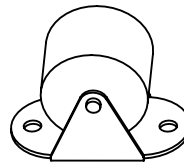

Ø40 x H-49

H x 8

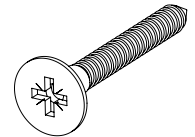

Ø4 x 35 mm

J x 4

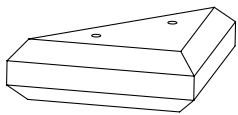

105 x 105 x 35 mm

K x 14

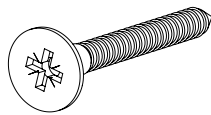

Ø5 x 35 mm

L x 4

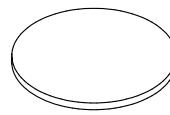

Ø30 x 2 mm

M x 2

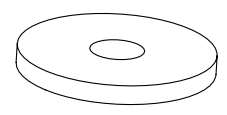

Ø40 x 3 mm

N x 1

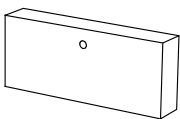

100 x 46 x 22 mm

P x 2

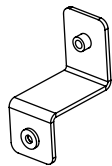

70 x 50 x 25 mm

R x 2

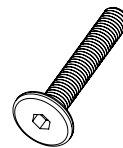

M6 x 35 mm

S x 1

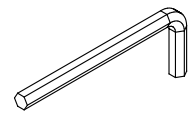

4 mm

T x 8

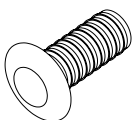

Ø8 x 22 mm

U x 2



M6 x 20 mm

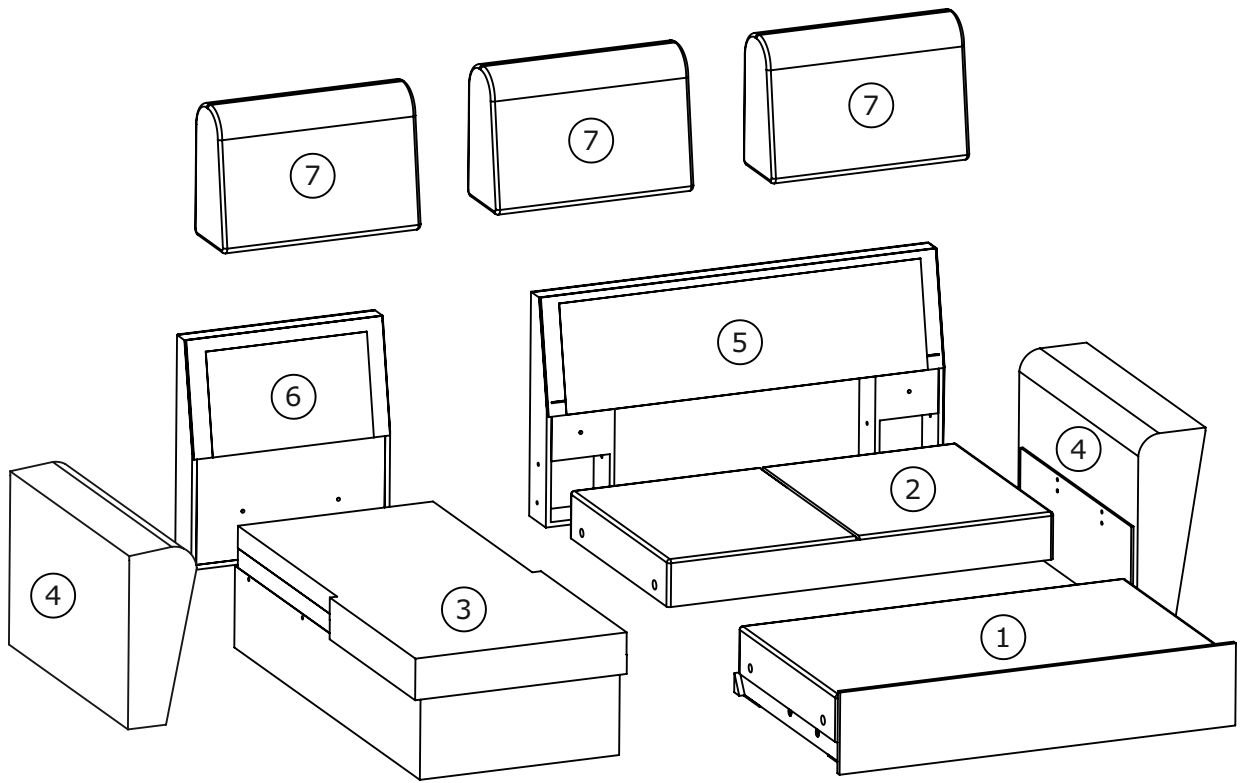
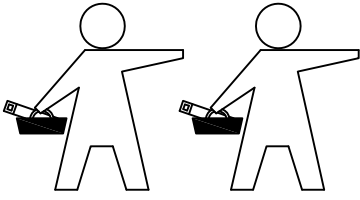

Box 1/3:

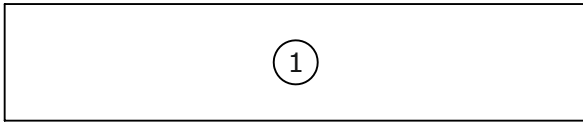

1270 x 250 x 720 mm

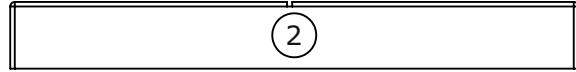

1290 x 740 x 150 mm

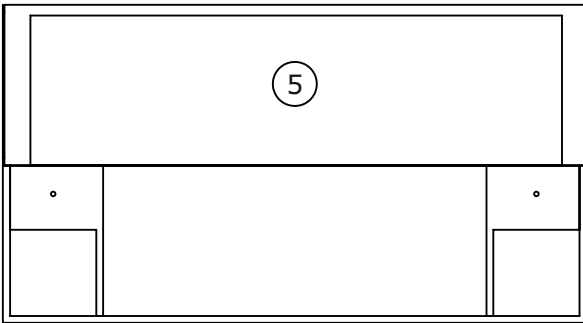

1280 x 700 x 110 mm

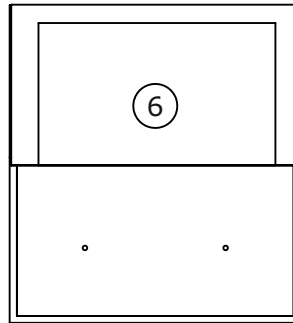

670 x 700 x 110 mm

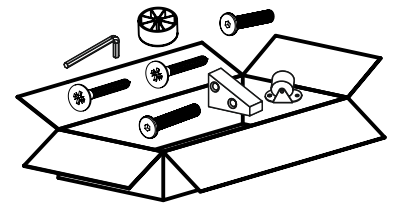

Box 2/3:

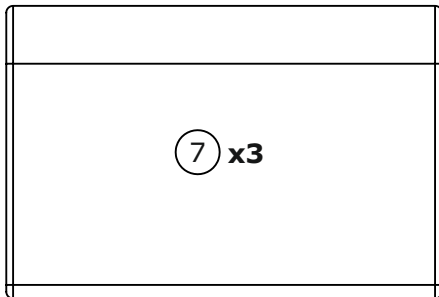

660 x 220 x 440 mm

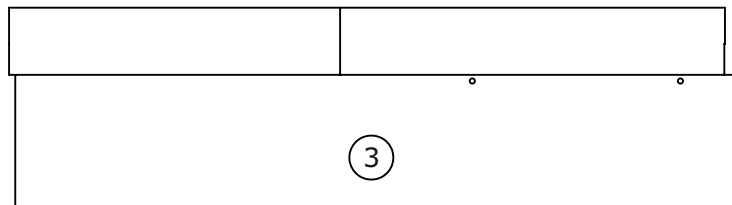

1450 x 710 x 420 mm

Box 3/3:

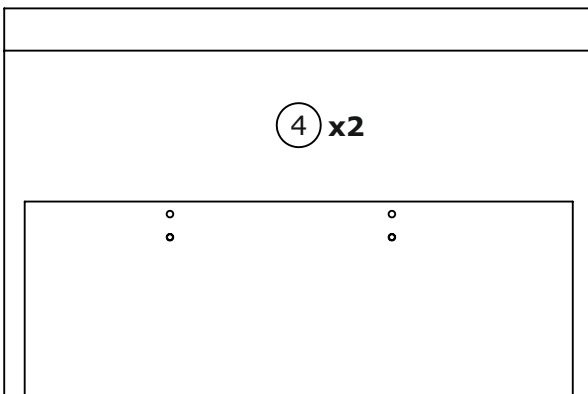

850 x 610 x 230 mm

1

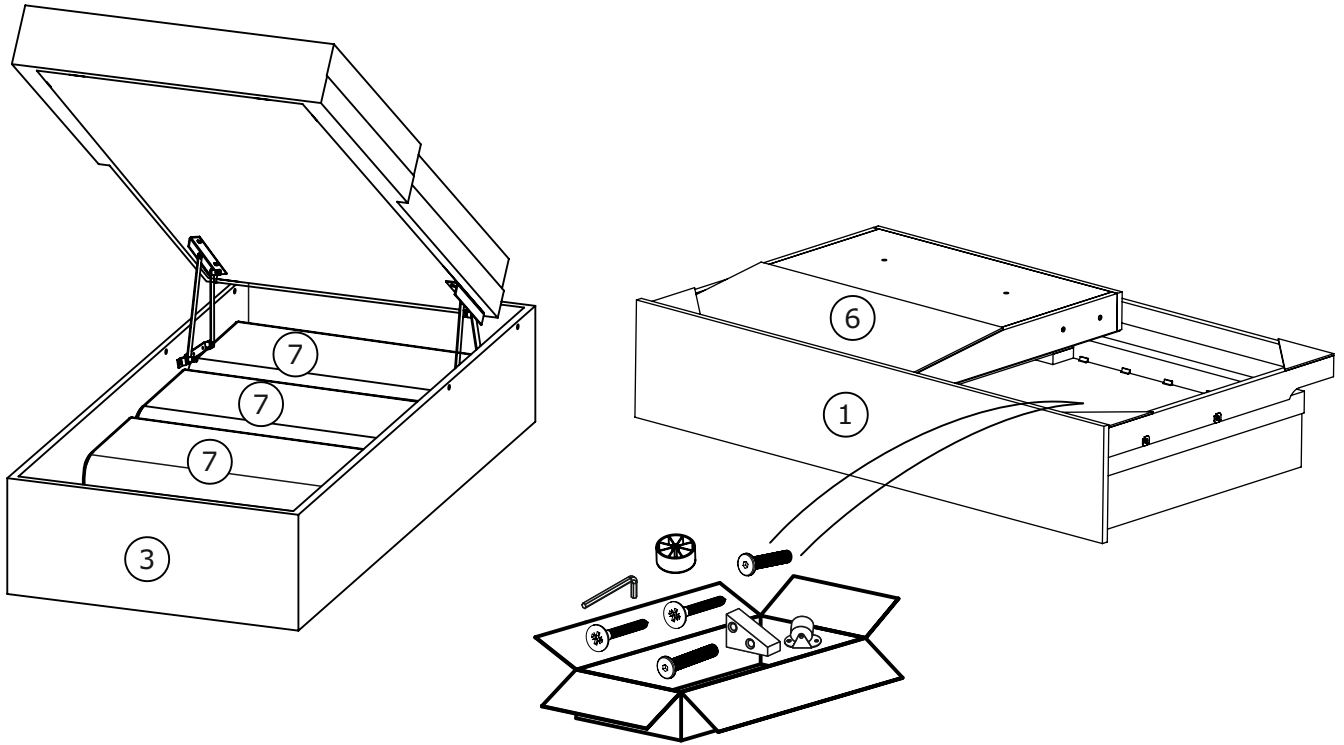

2

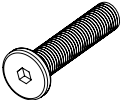
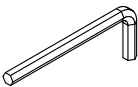
<p>B x 2</p>  <p>M8 x 50 mm</p>	<p>F x 1</p>  <p>5 mm</p>	
--	--	--

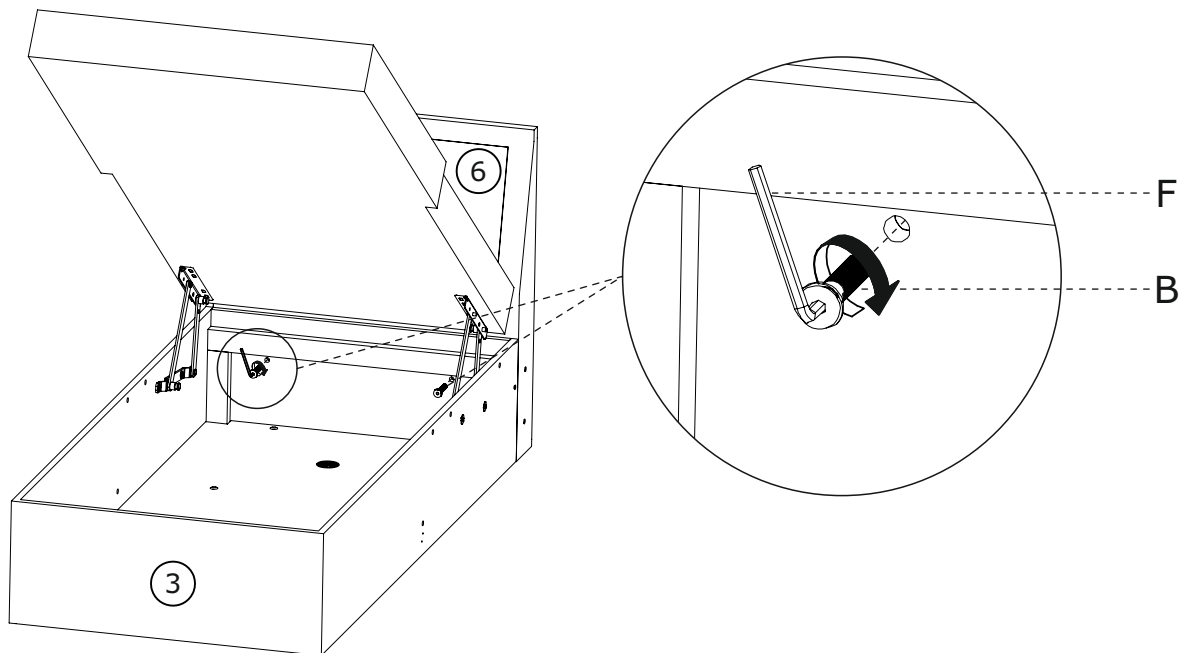

3

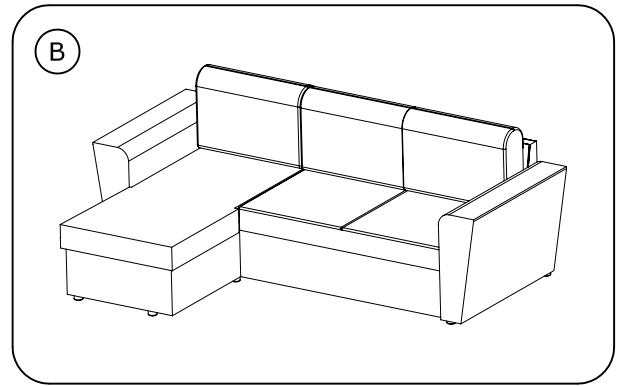
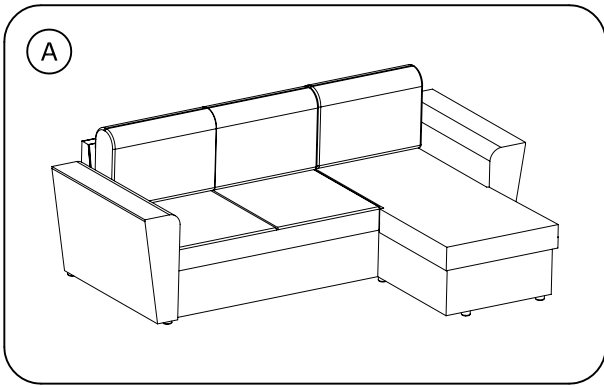
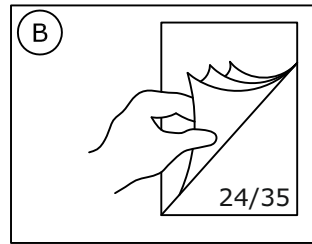
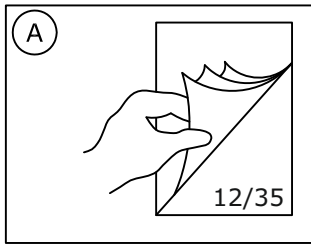

4

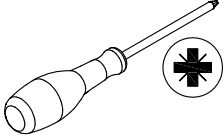
<p>D x 2</p>  <p>Ø5x30 mm</p>	<p>E x 1</p>  <p>35x24x15 mm</p>	
--	---	---

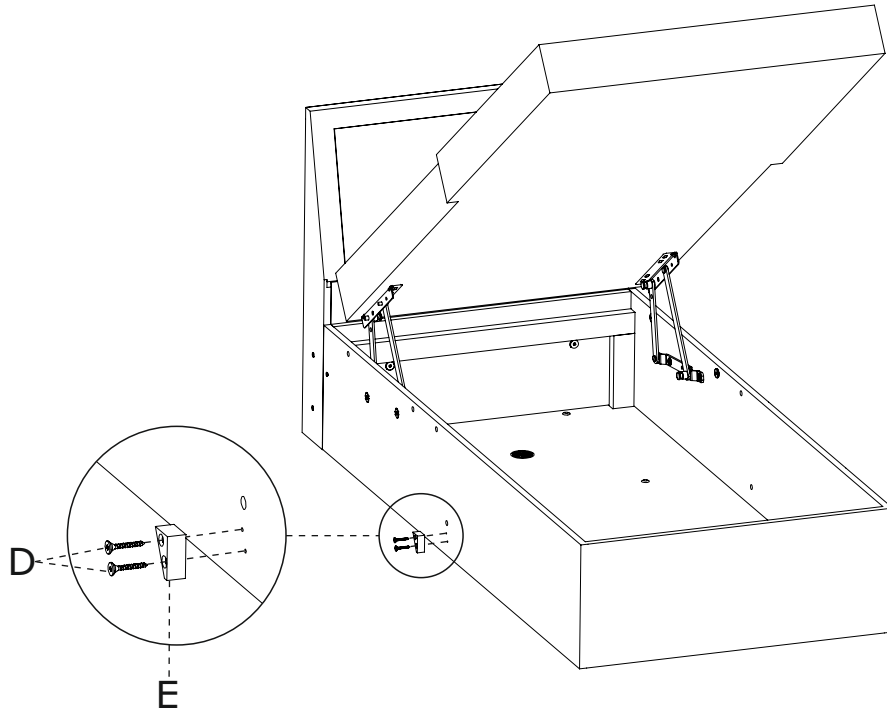
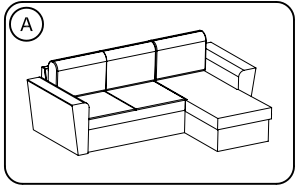

5

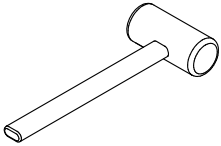
<p>T x 8</p>  <p>Ø8x22mm</p>	
---	---

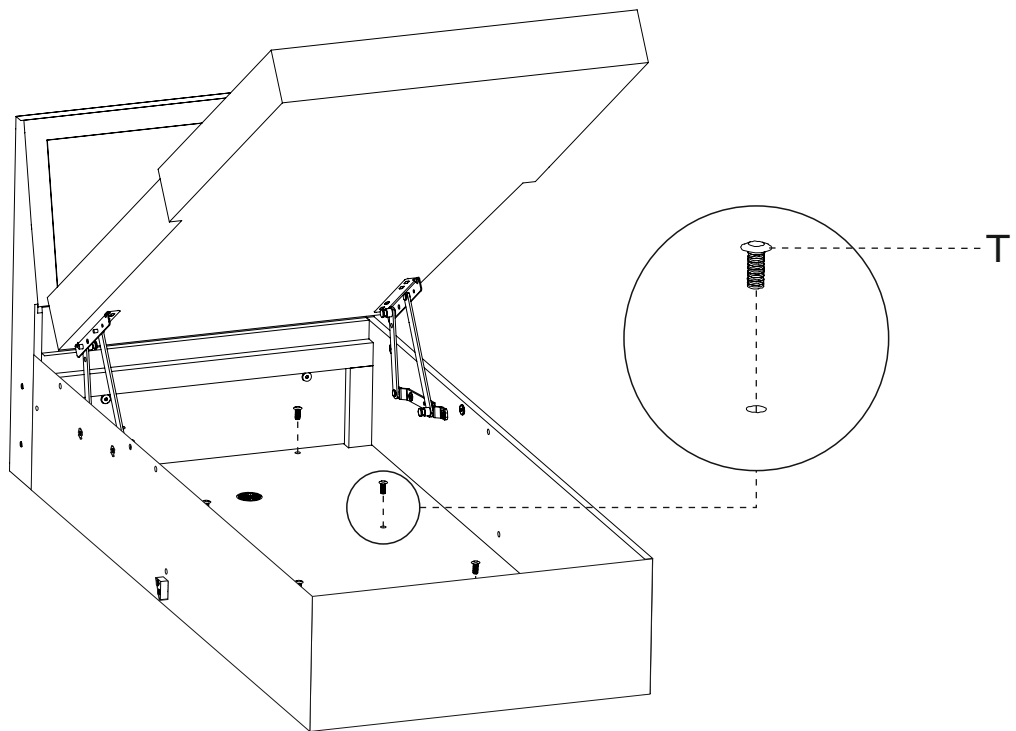

6

B x 3 M8 x 50 mm	F x 1 5 mm
---------------------	---------------

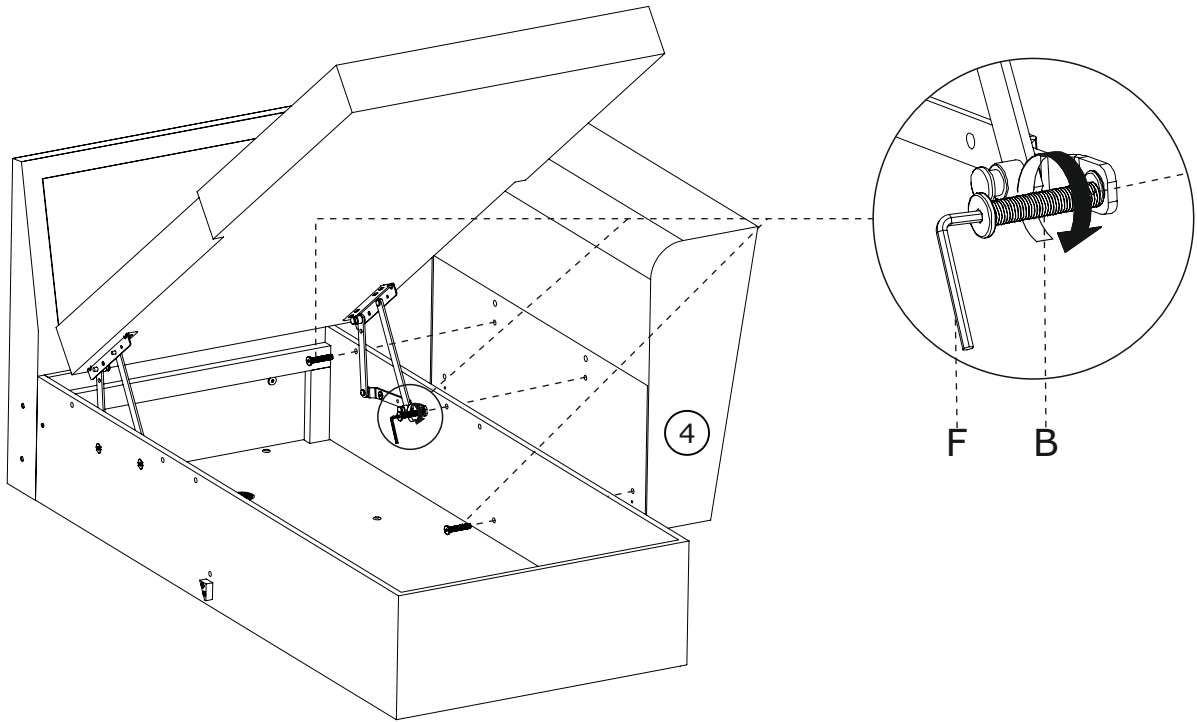

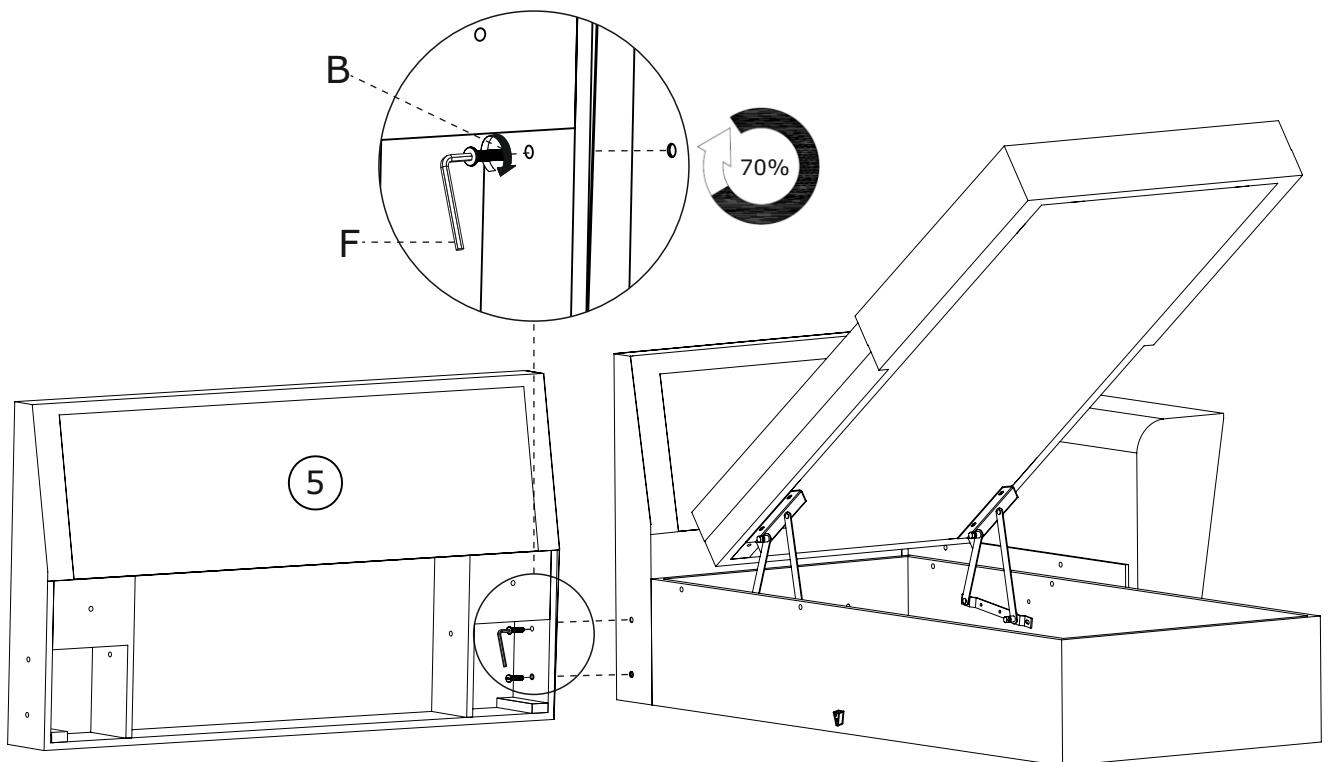

7

B x 2 M8 x 50 mm	F x 1 5 mm
---------------------	---------------

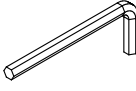

8

P x 2  70x50x25 mm	R x 2  M6x35 mm	S x 1  4 mm	
---	--	--	--

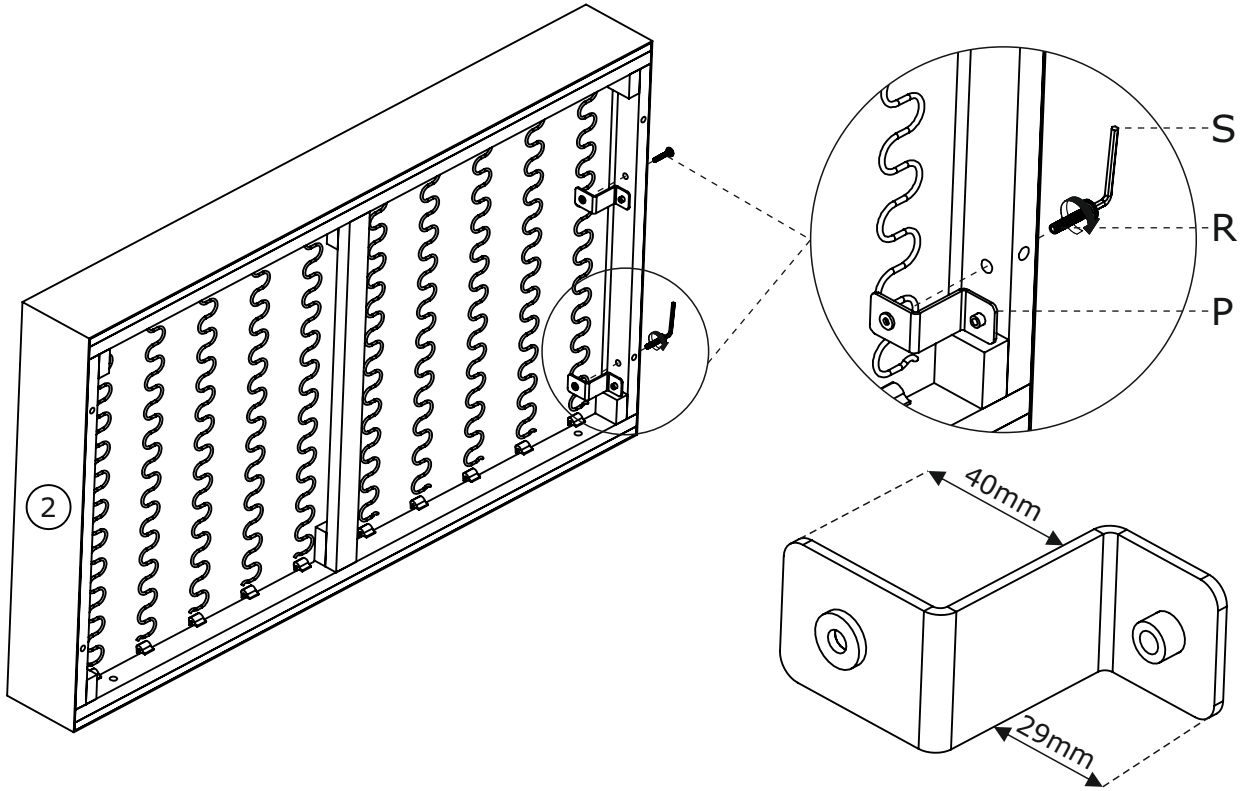

9

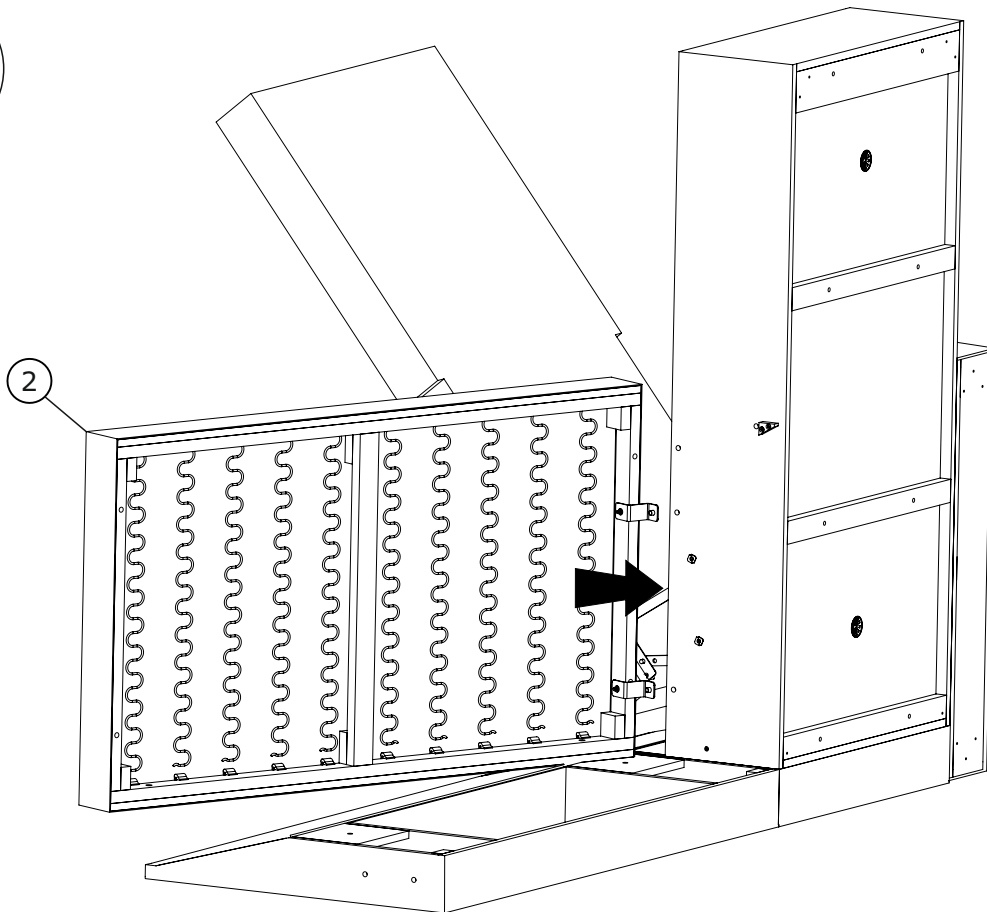

10

U x 2  M6x20 mm	S x 1  4 mm	
--	--	--

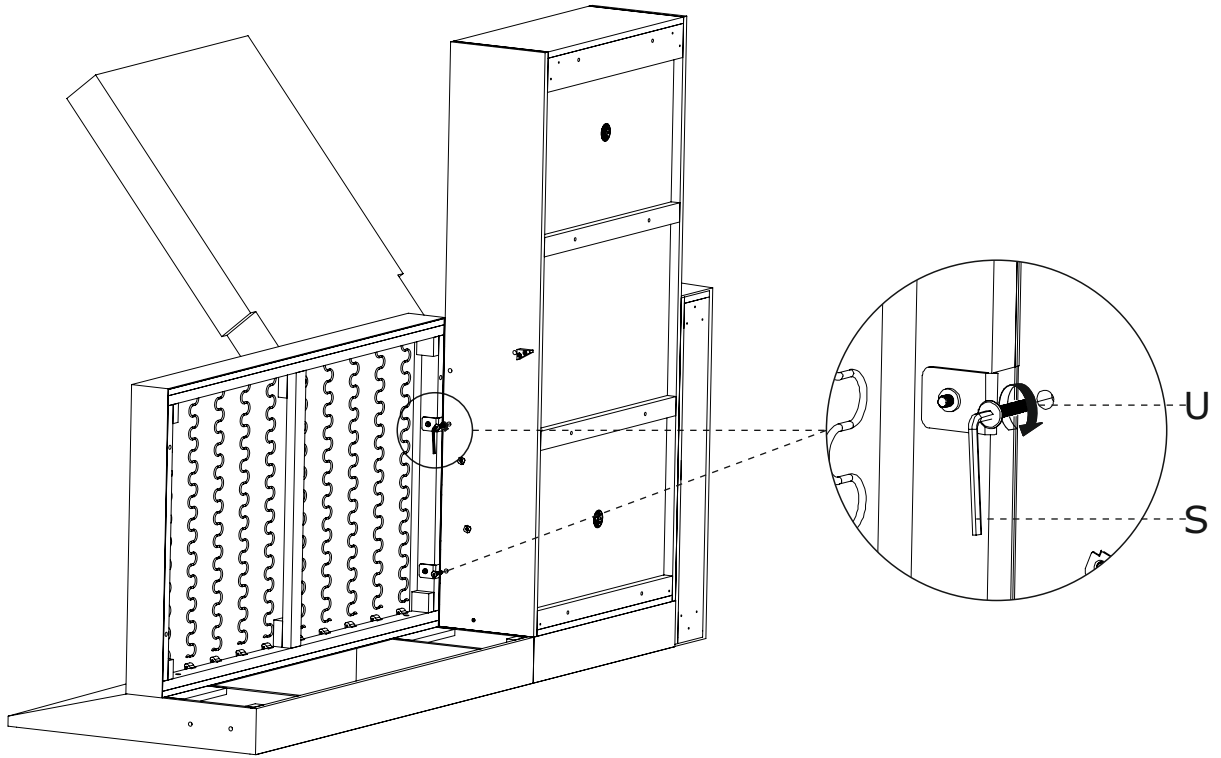

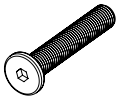
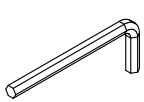

11

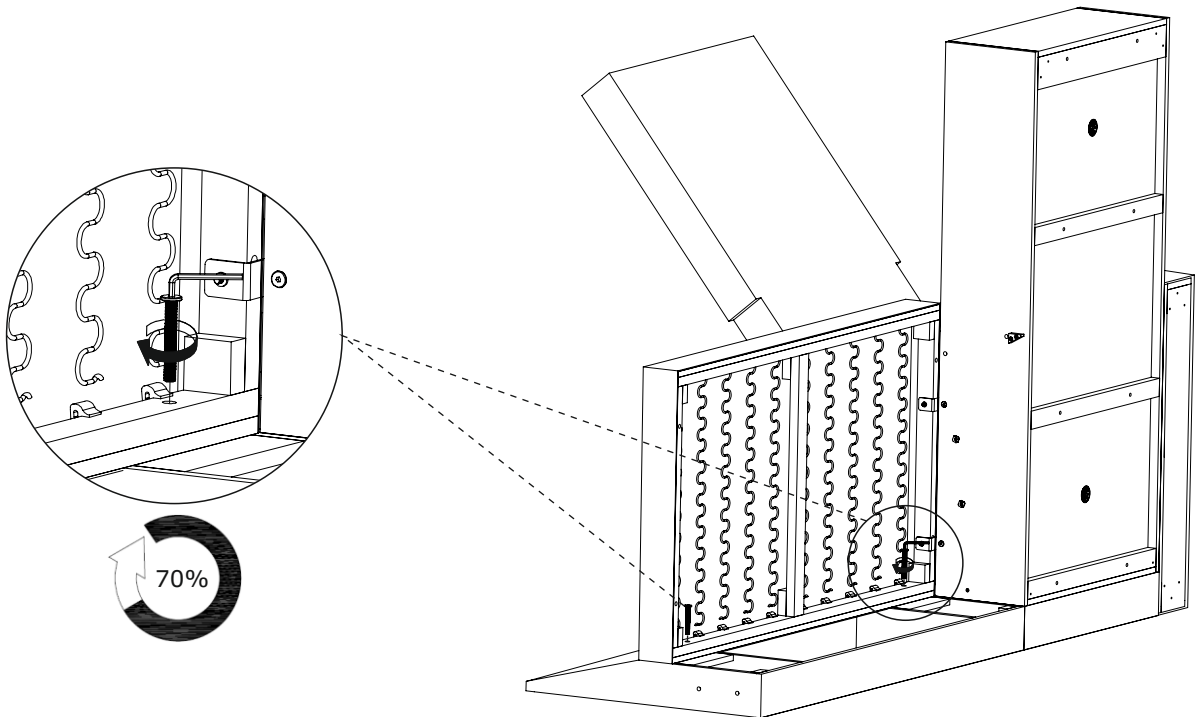
A x 2  M8 x 75 mm	F x 1  5 mm	
--	--	--

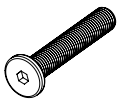
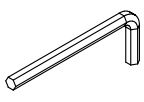

12

A x 2  M8 x 75 mm	F x 1  5 mm	M x 2  Ø40 x 3 mm
--	--	--

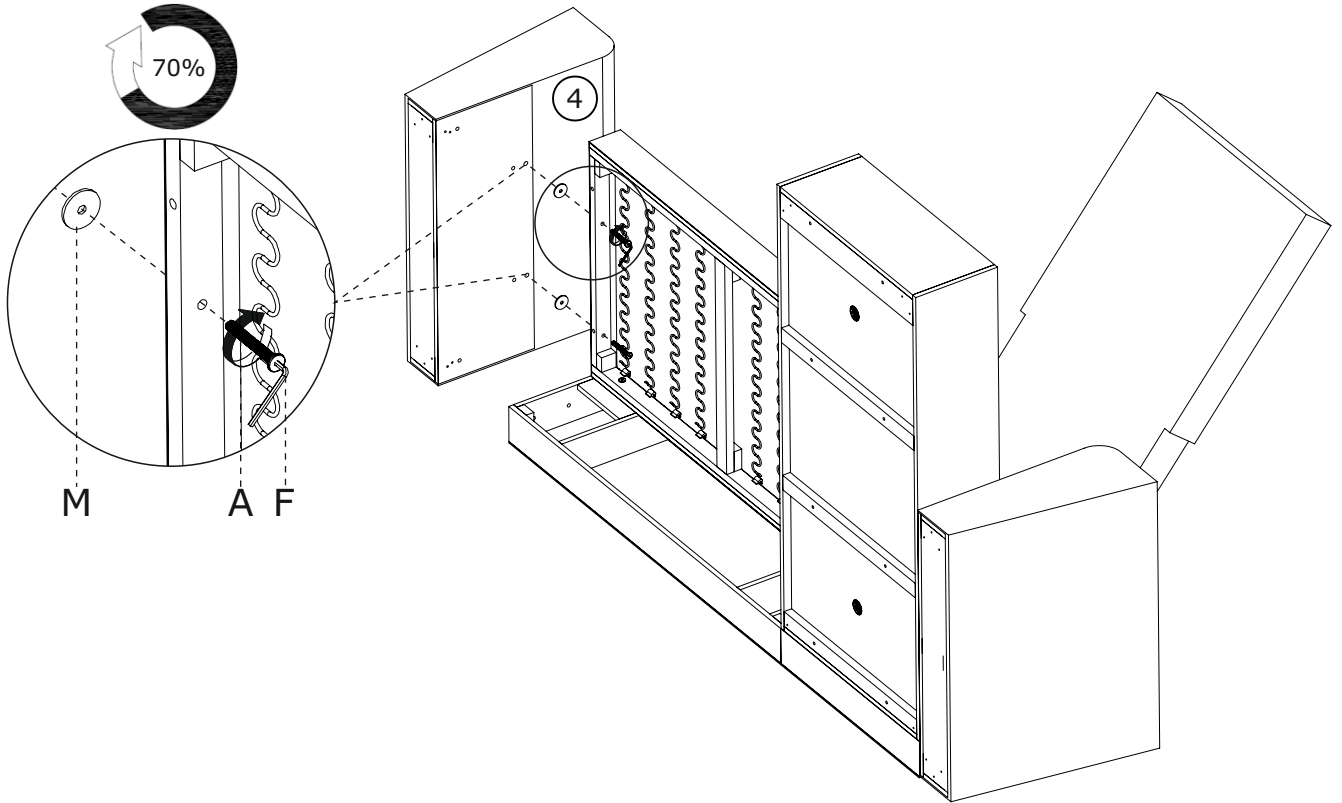

13

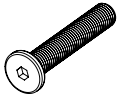
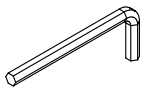
B x 1  M8 x 50 mm	F x 1  5 mm
--	--

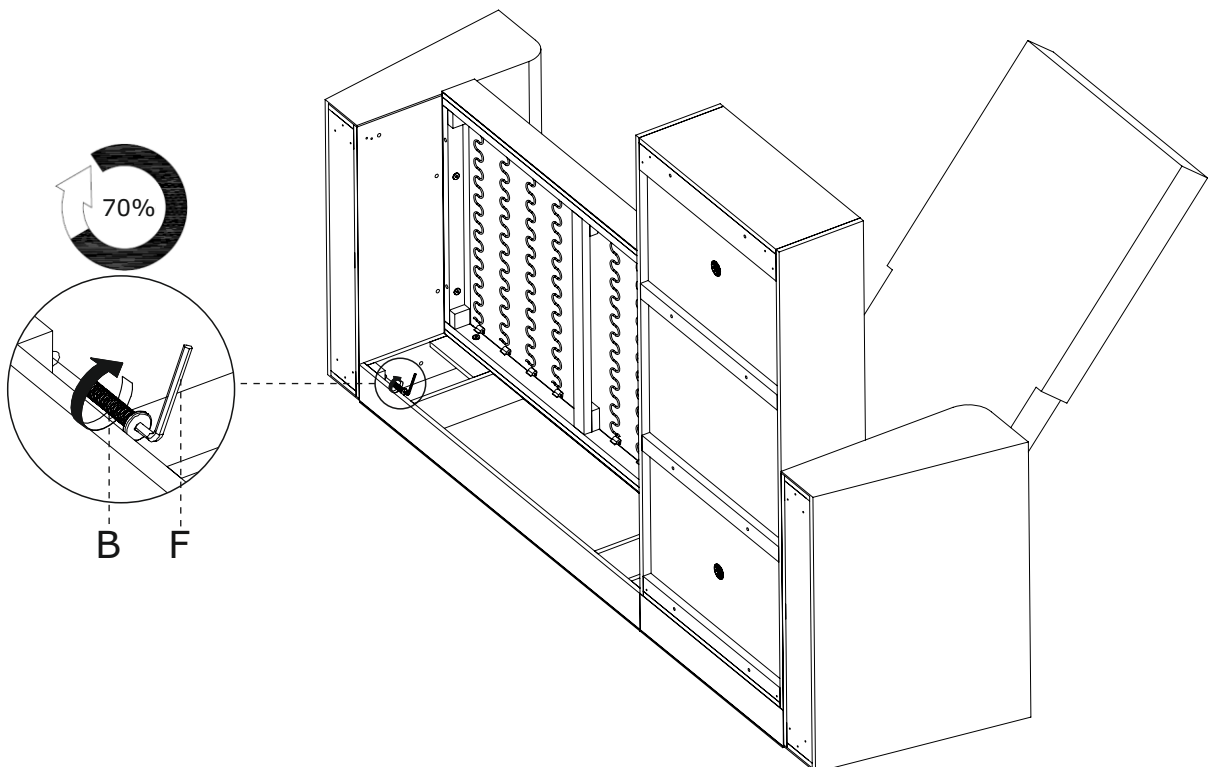

14

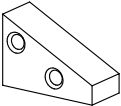
<p>K x 2</p>  <p>Ø5 x 35 mm</p>	<p>E x 1</p>  <p>35x24x15 mm</p>	
--	---	---

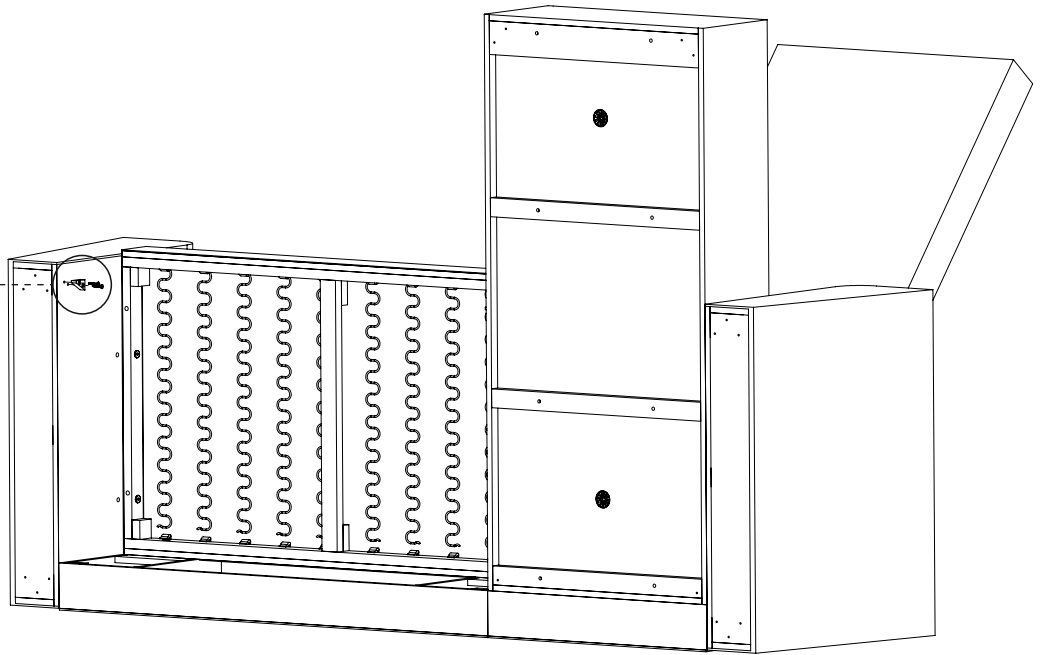
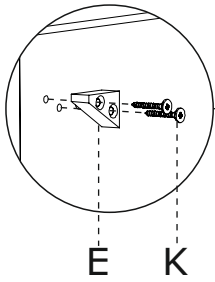

15

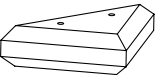
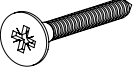
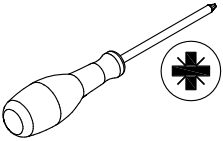
<p>C x 4</p>  <p>Ø50 x 35 mm</p>	<p>J x 4</p>  <p>105x105x35mm</p>	<p>K x 12</p>  <p>Ø5 x 35 mm</p>	
---	--	---	---

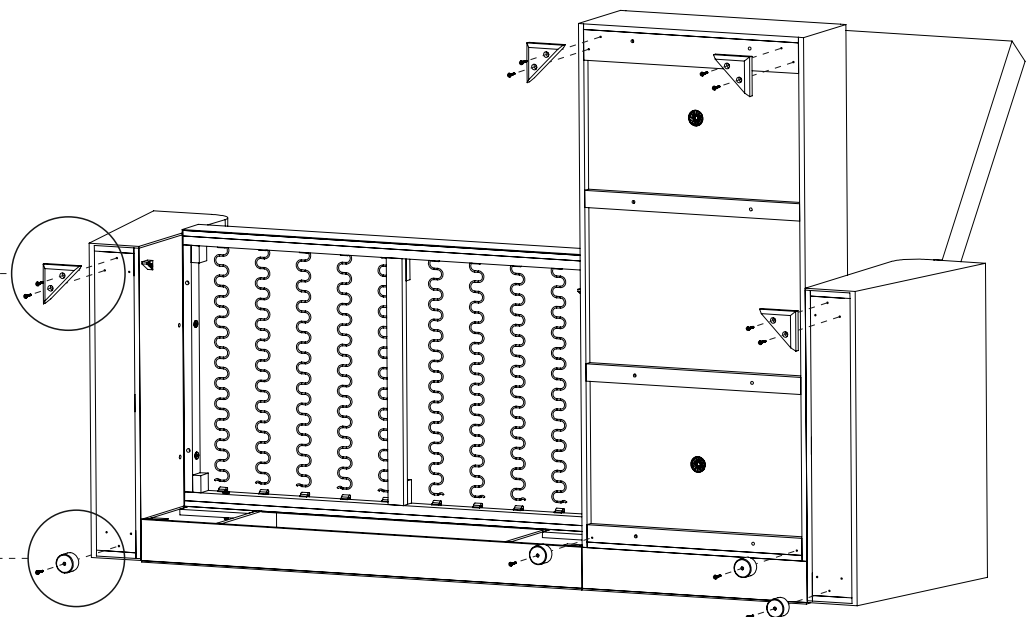
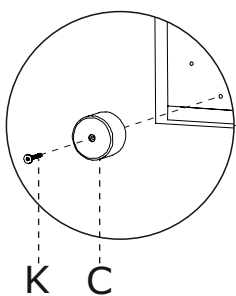
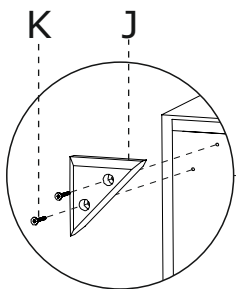

16

L x 4



Ø30 x 2 mm

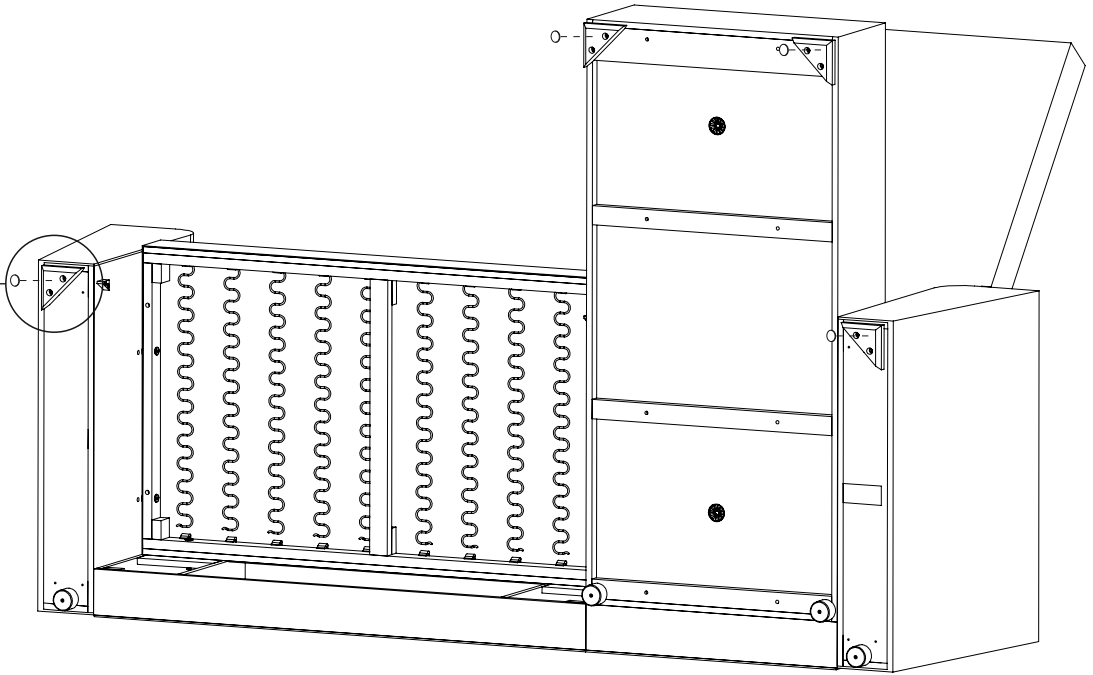
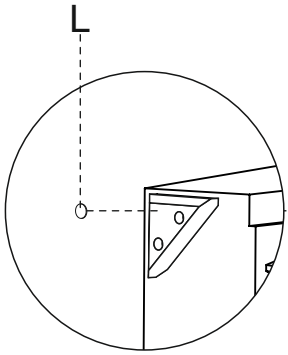

17

F x 1

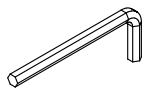

5 mm

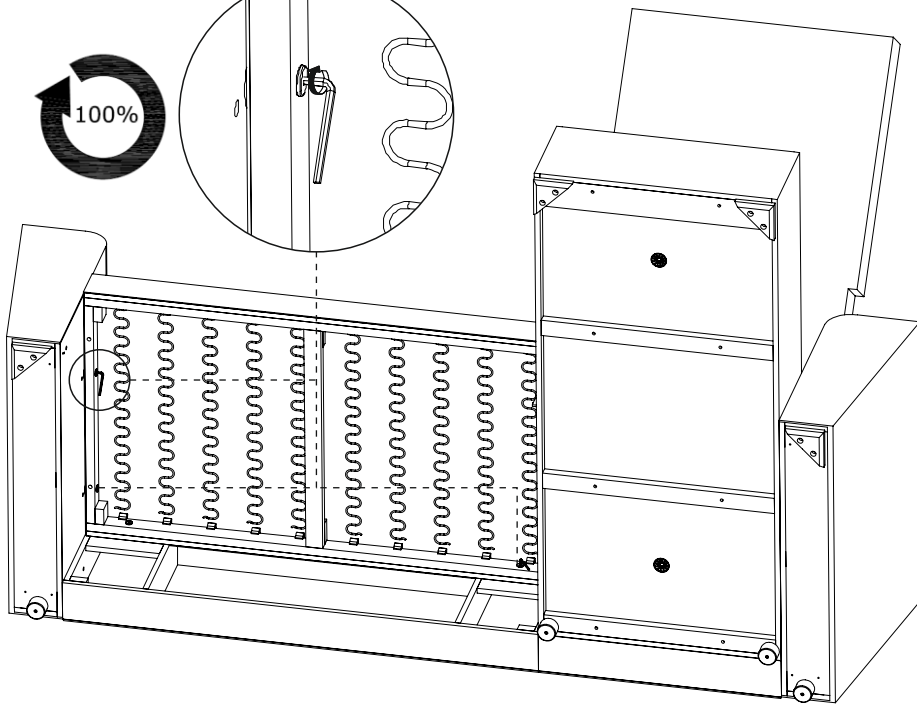
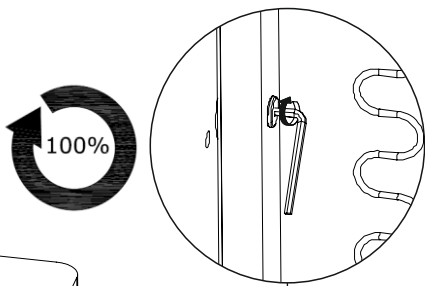

18

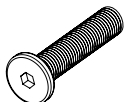
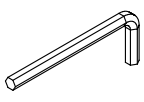
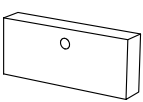
<p>B x 1</p>  <p>M8 x 50 mm</p>	<p>F x 1</p>  <p>5 mm</p>	<p>N x 1</p>  <p>100x46x22 mm</p>
--	--	--

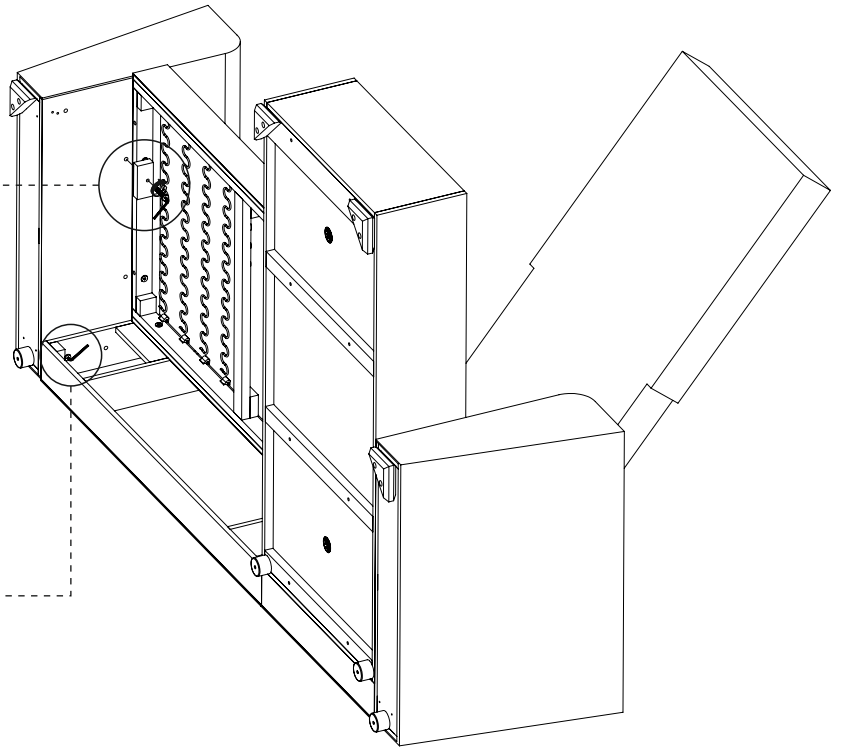
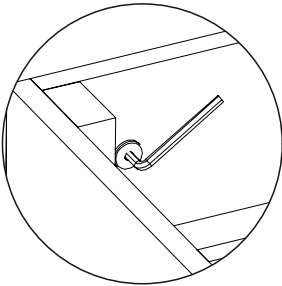
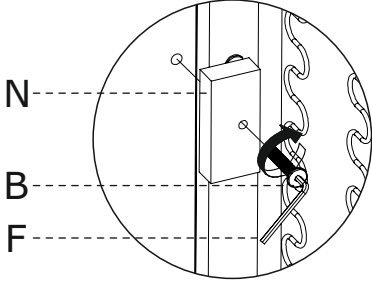

19

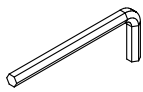
<p>F x 1</p>  <p>5 mm</p>	
--	--

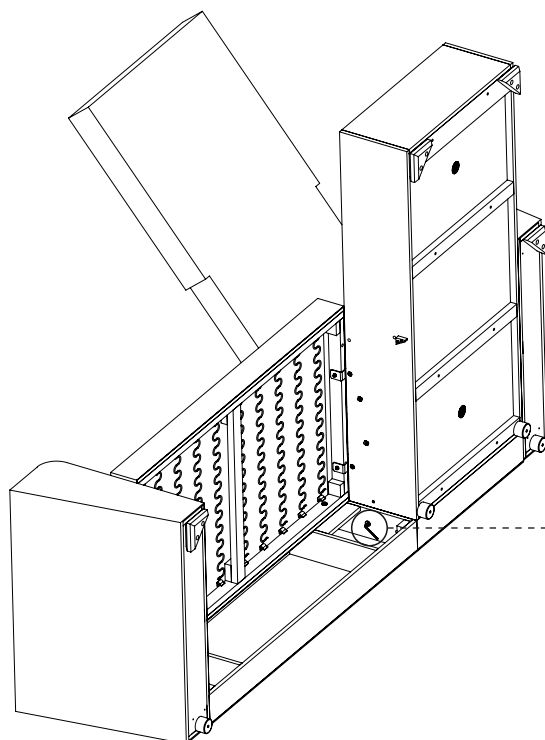
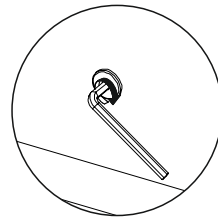

20

<p>G x 4</p>  <p>Ø40 x H-49</p>	<p>H x 8</p>  <p>Ø4 x 35 mm</p>	
--	--	---

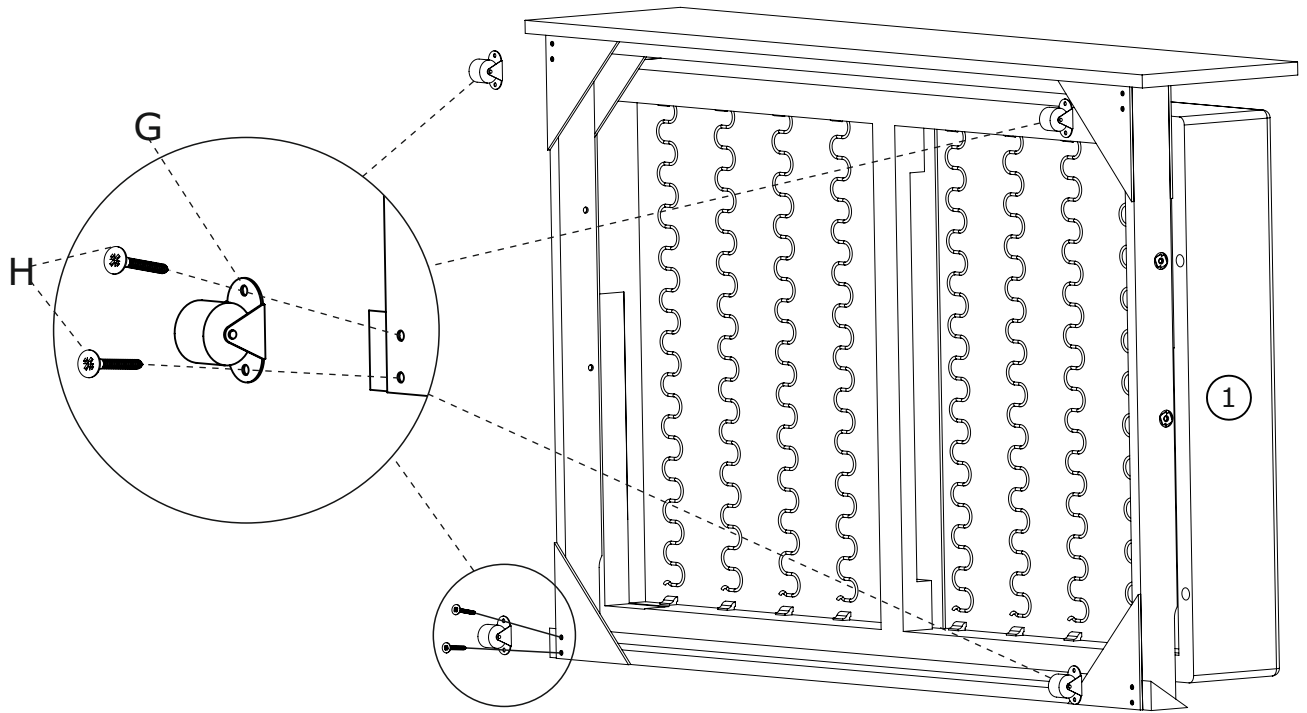

21

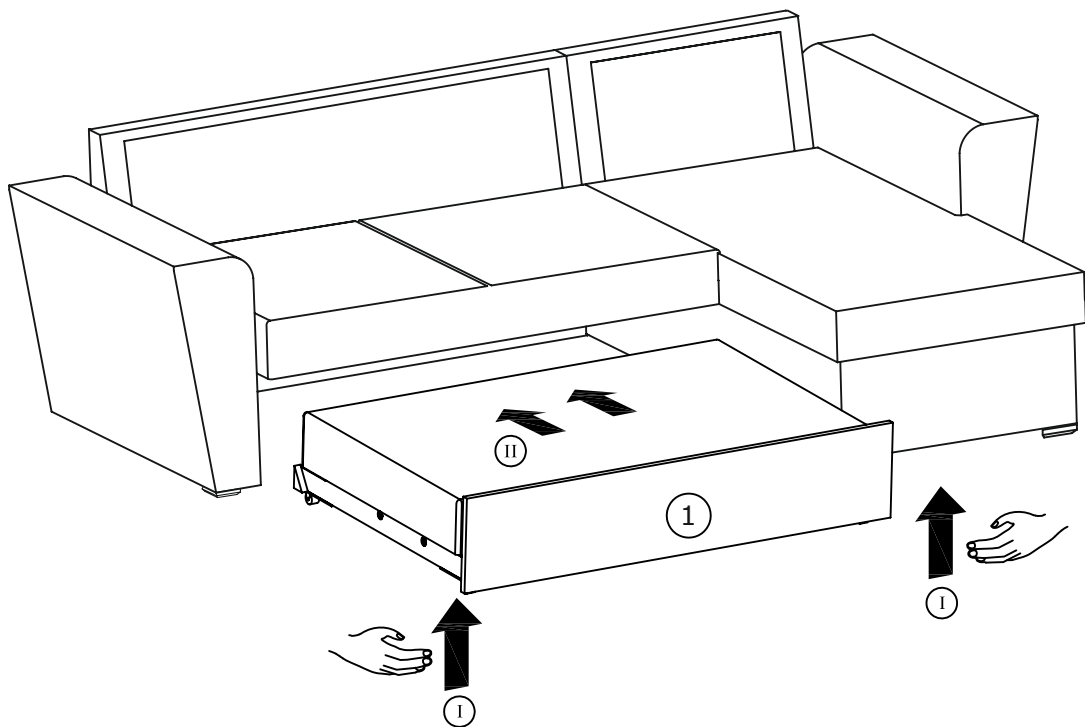

22

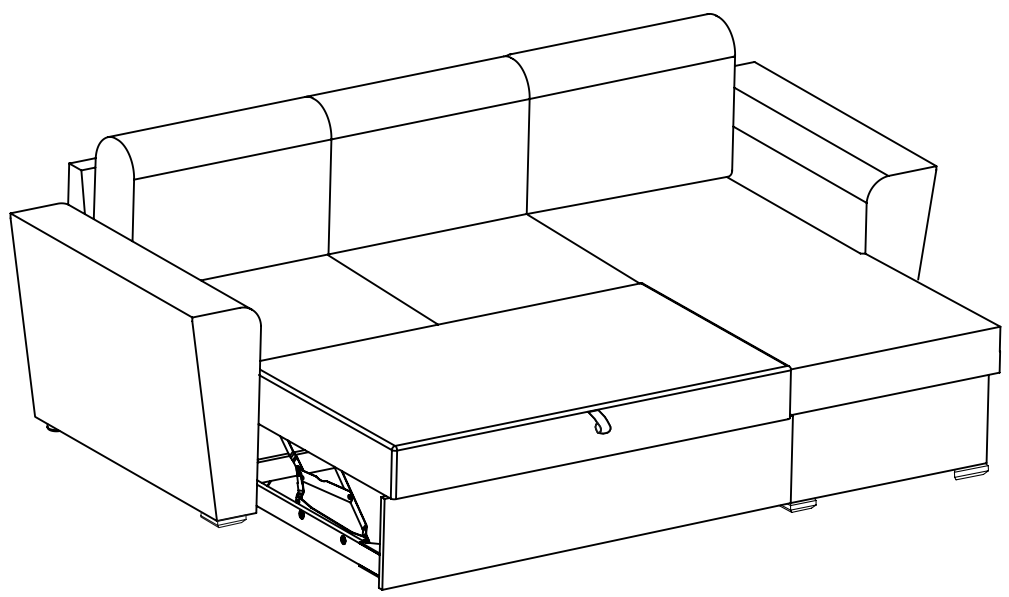
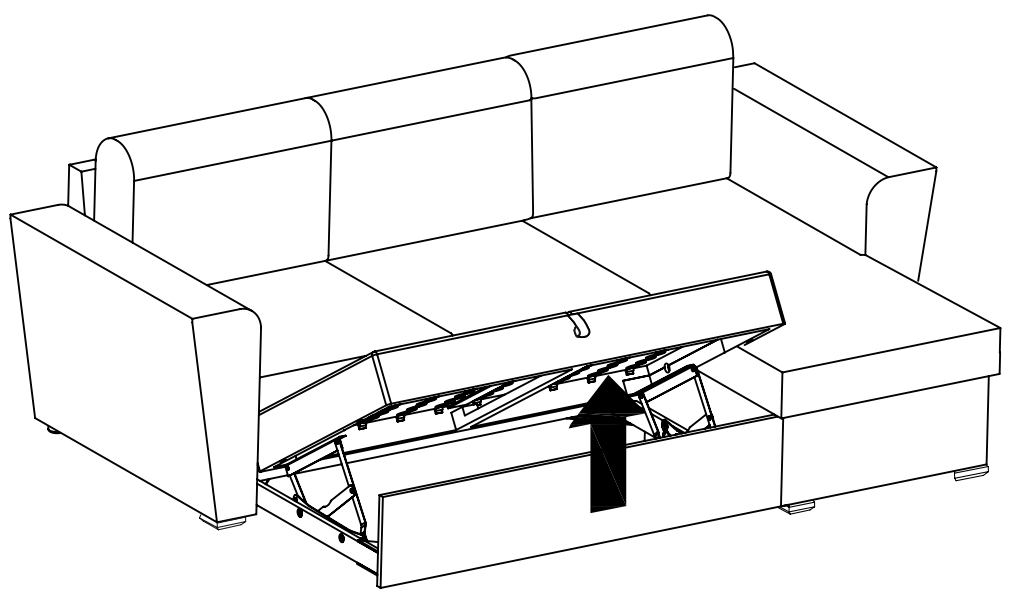
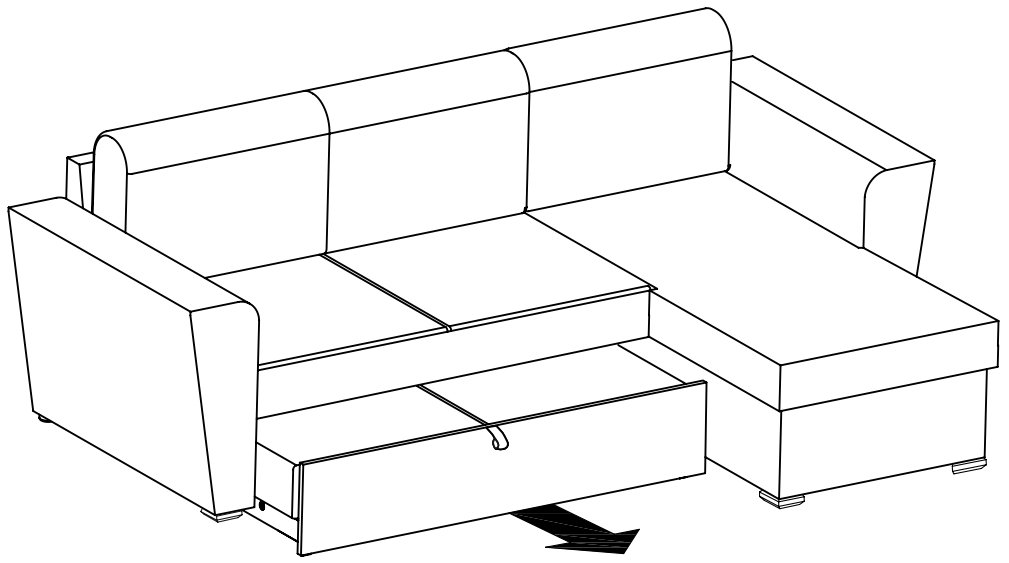

23

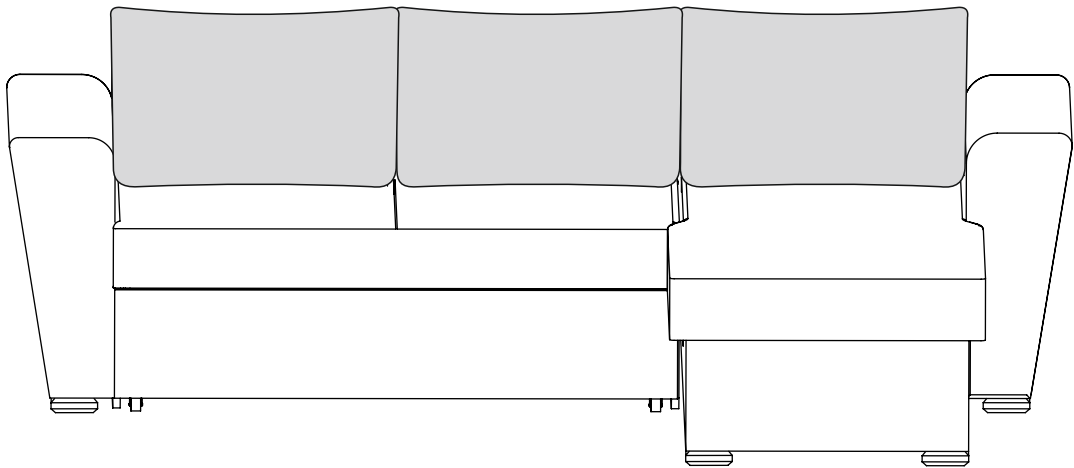
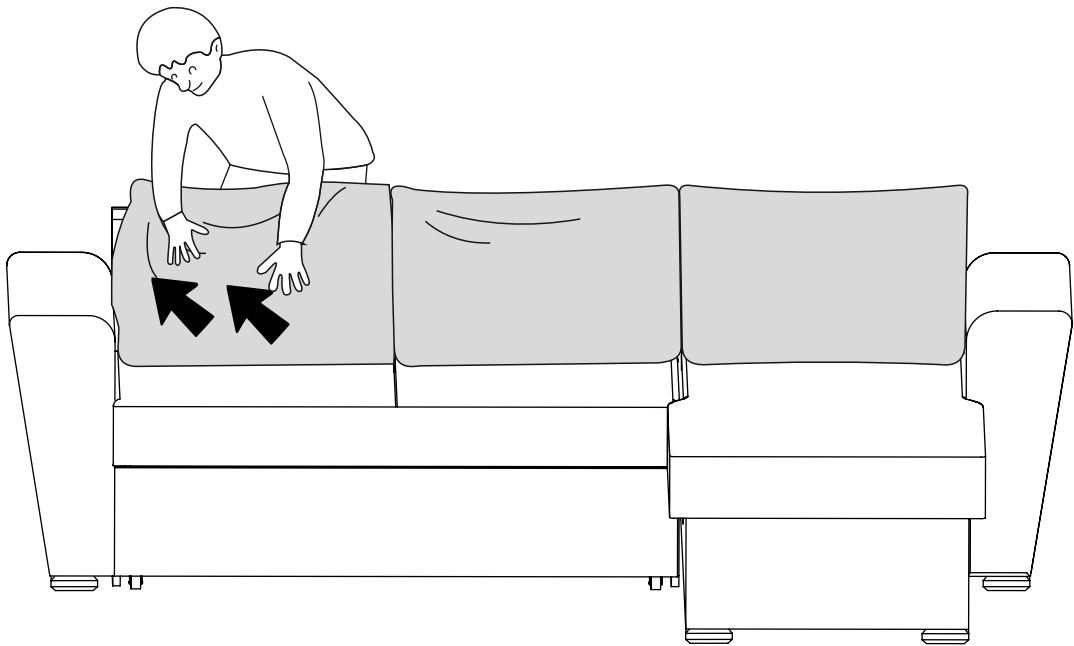
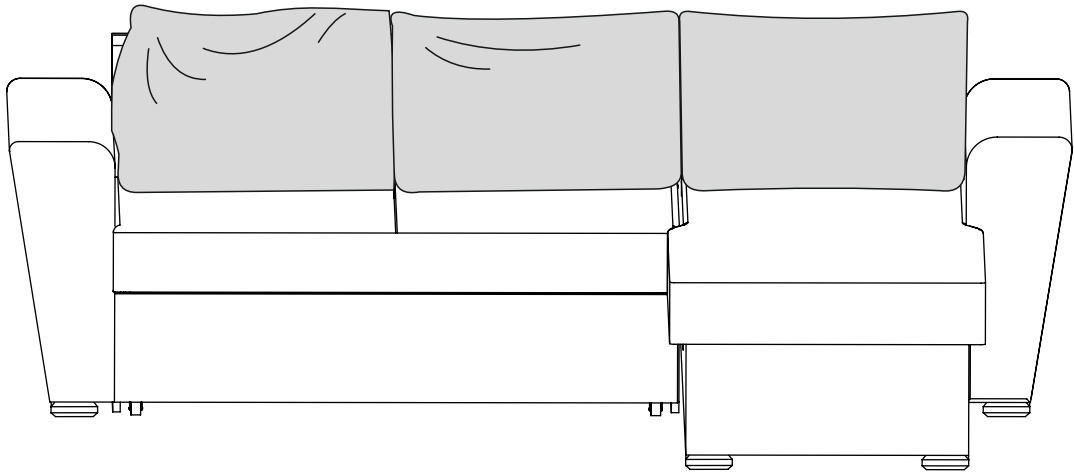

24

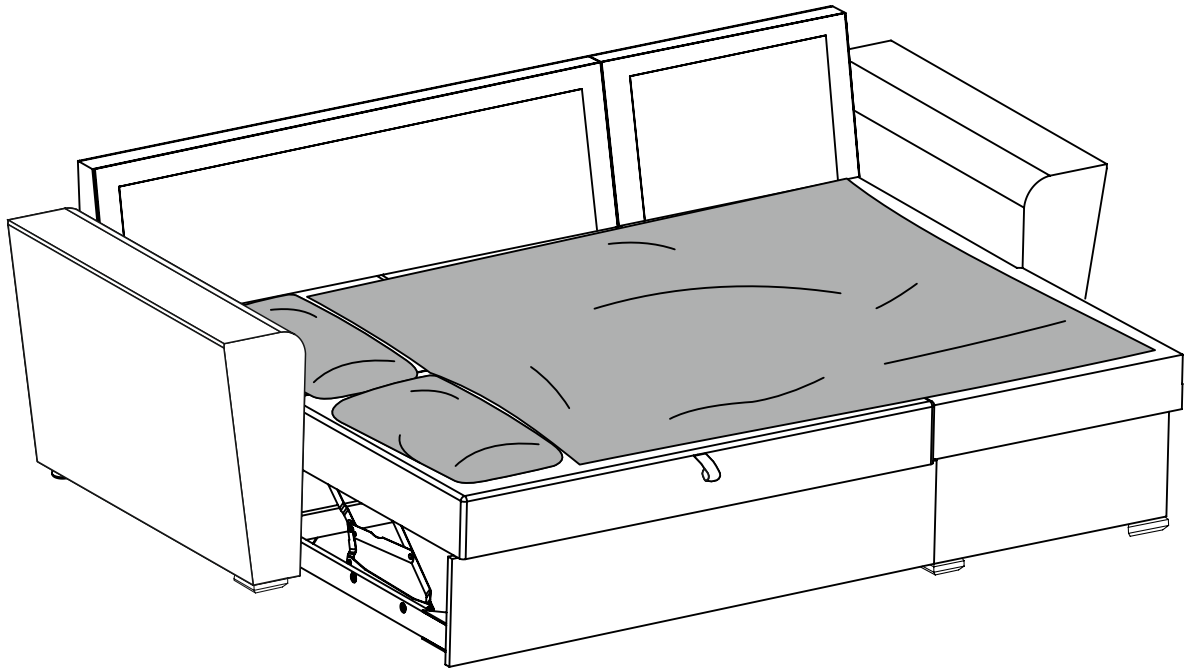
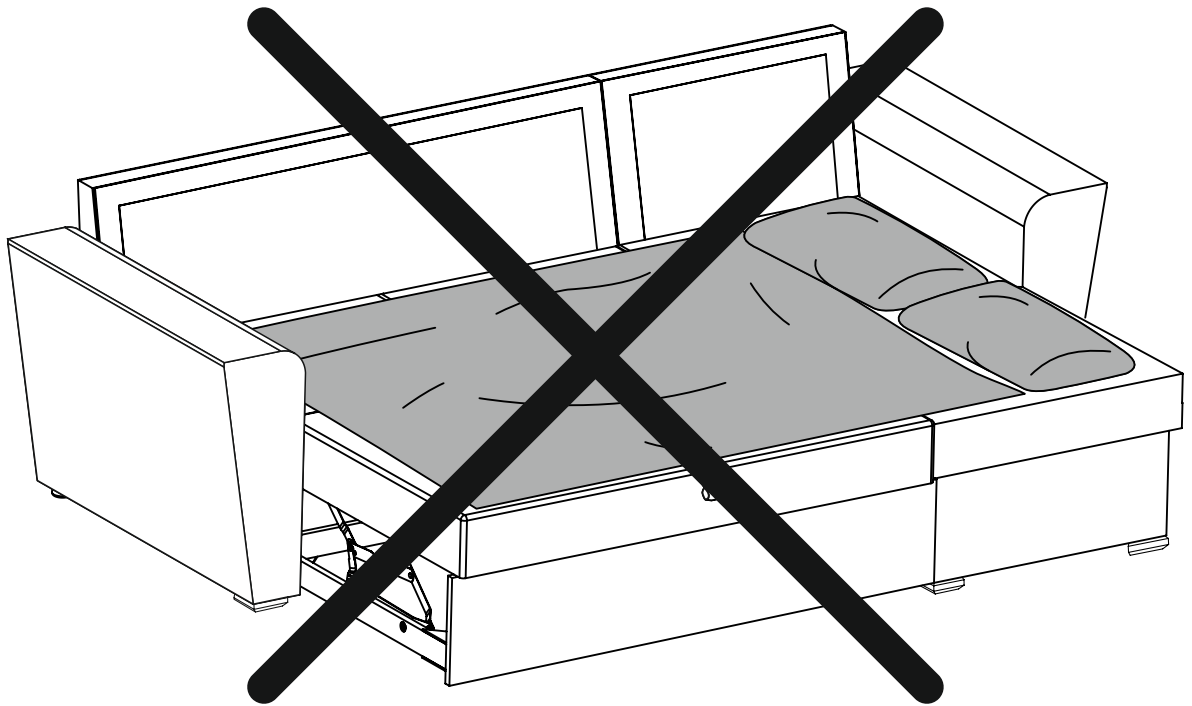

25

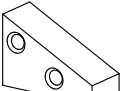
<p>D x 2</p>  <p>Ø5x30 mm</p>	<p>E x 1</p>  <p>35x24x15 mm</p>	
--	---	---

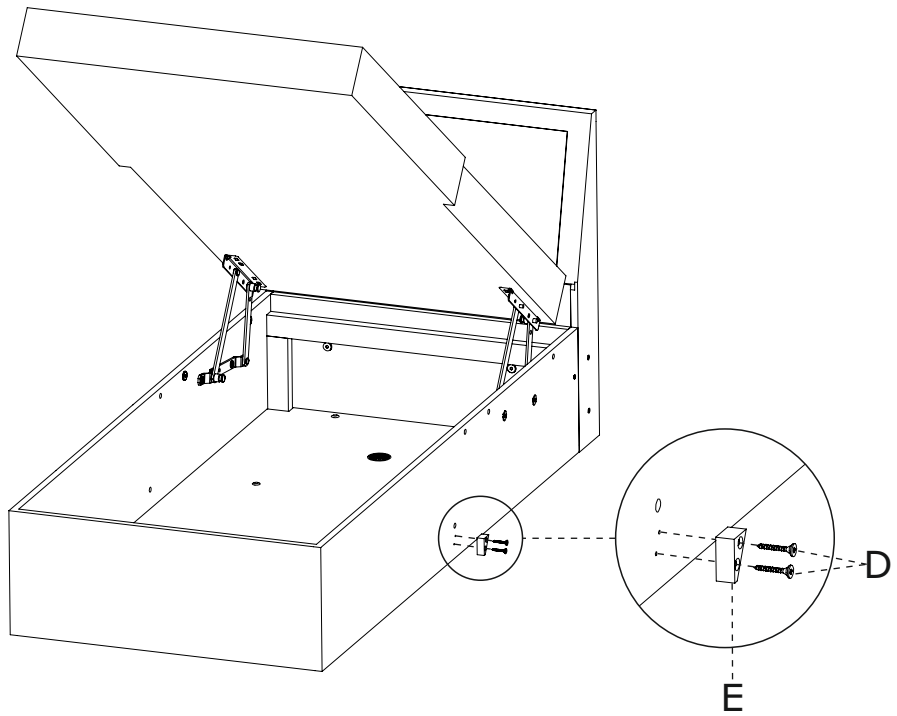
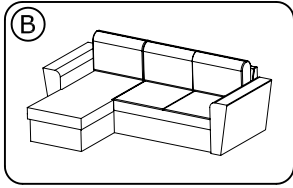

26

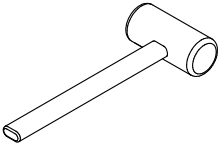
<p>T x 8</p>  <p>Ø8x22mm</p>	
---	---

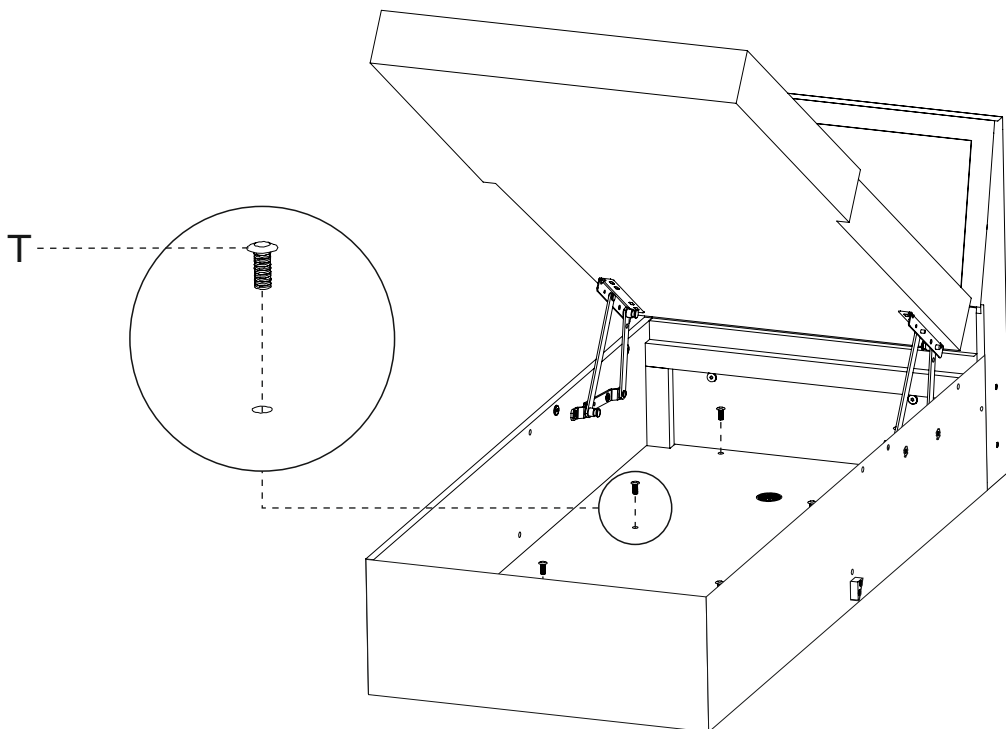

27

B x 3 M8 x 50 mm	F x 1 5 mm	
---------------------	---------------	--

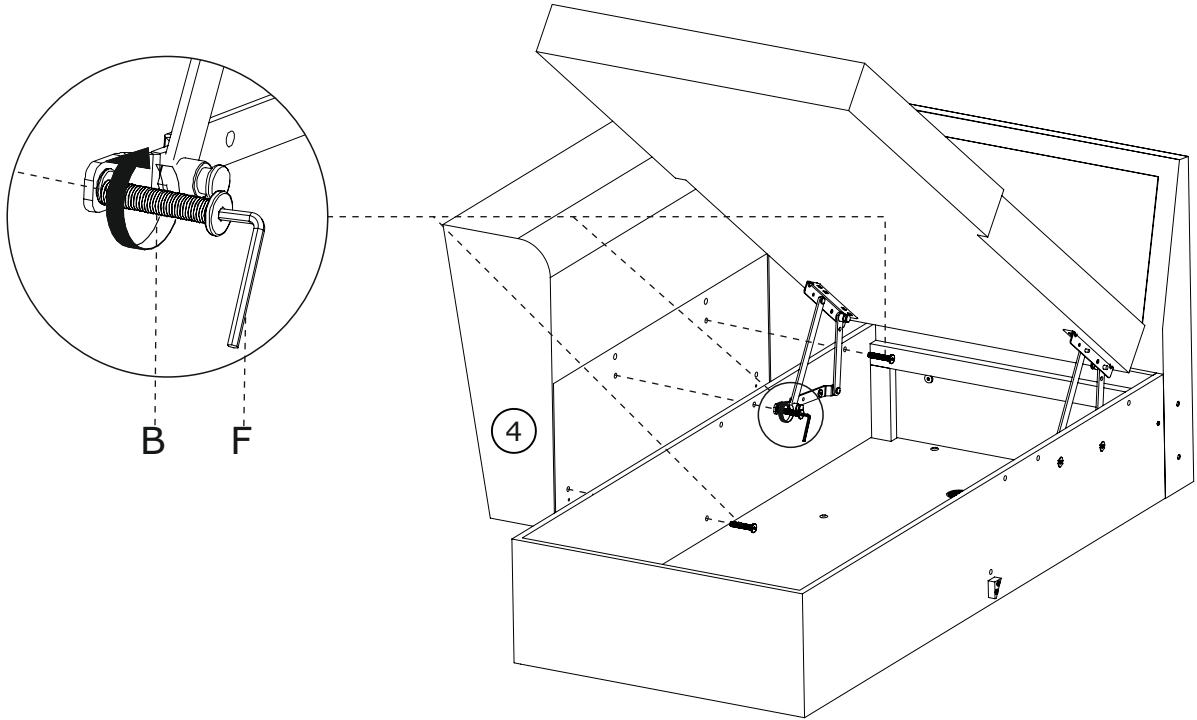

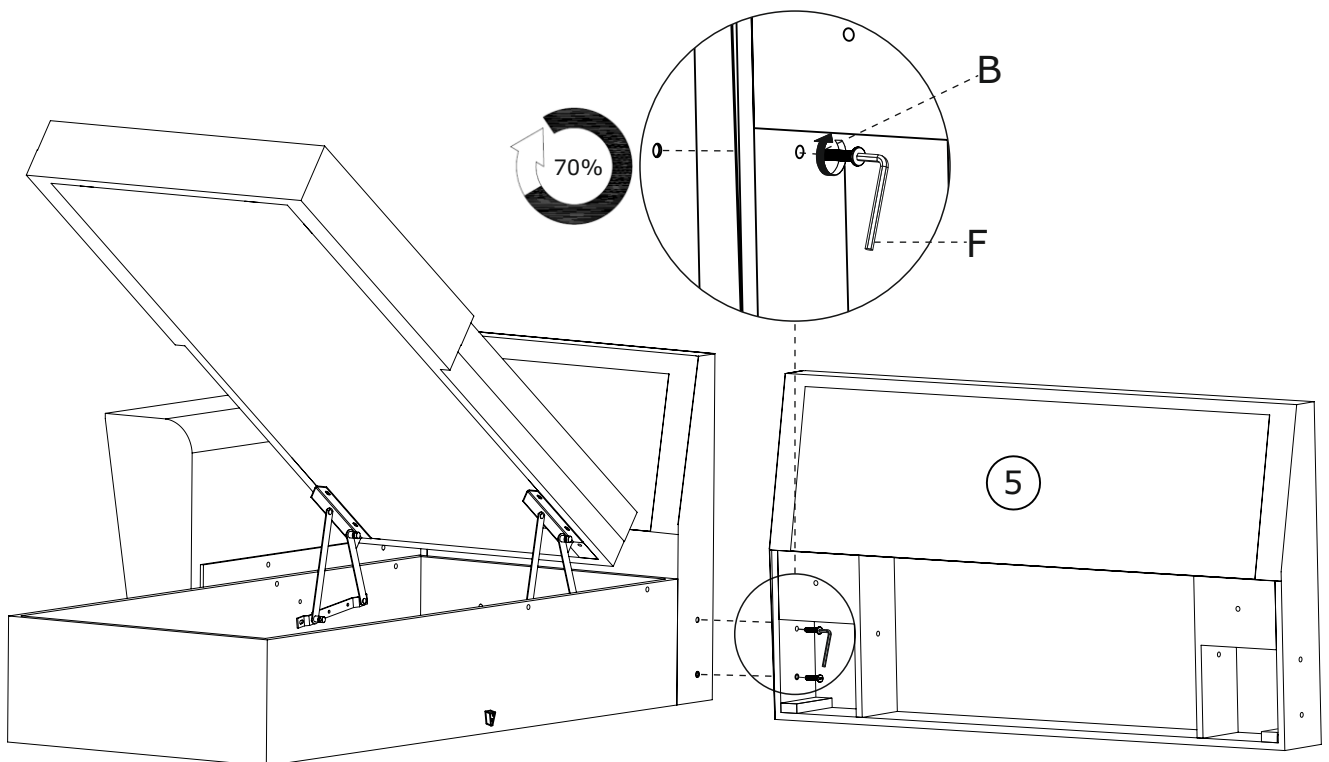

28

B x 2 M8 x 50 mm	F x 1 5 mm	
---------------------	---------------	--

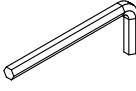

29

P x 2  70x50x25 mm	R x 2  M6x35 mm	S x 1  4 mm
---	--	--

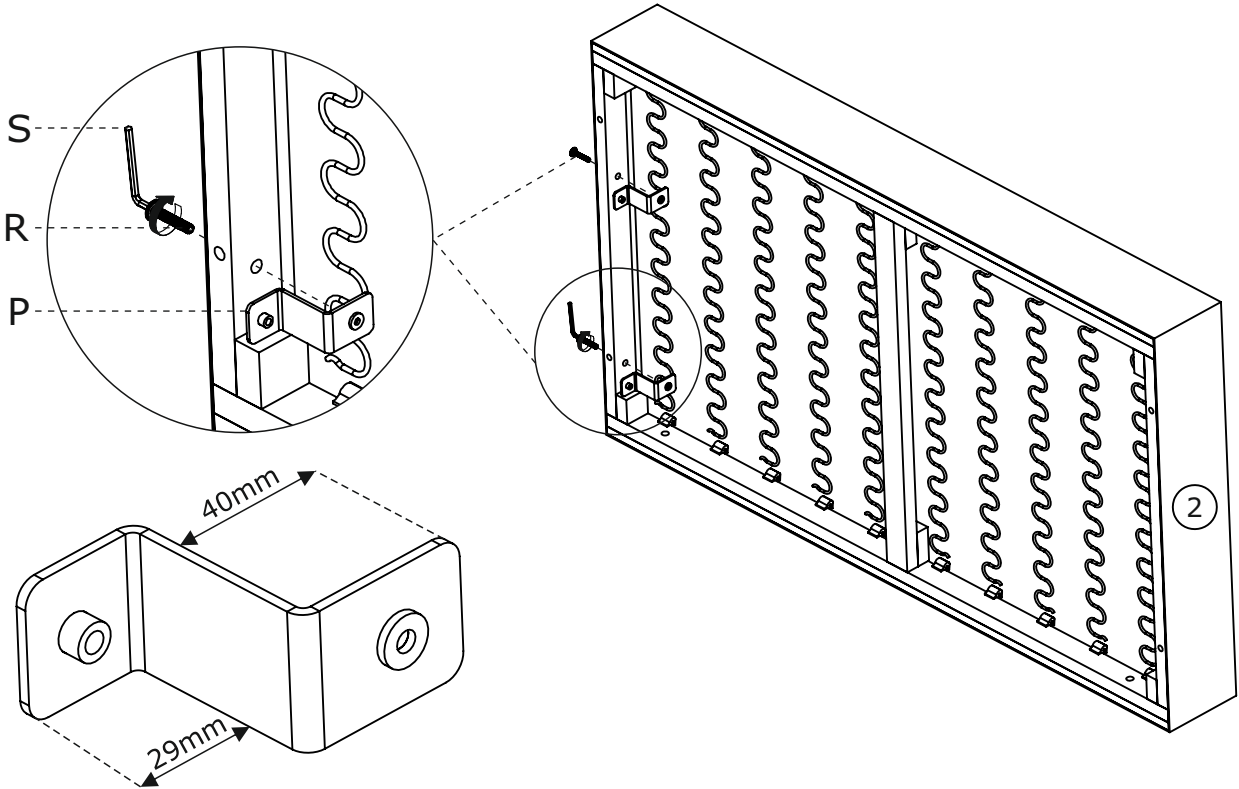

30

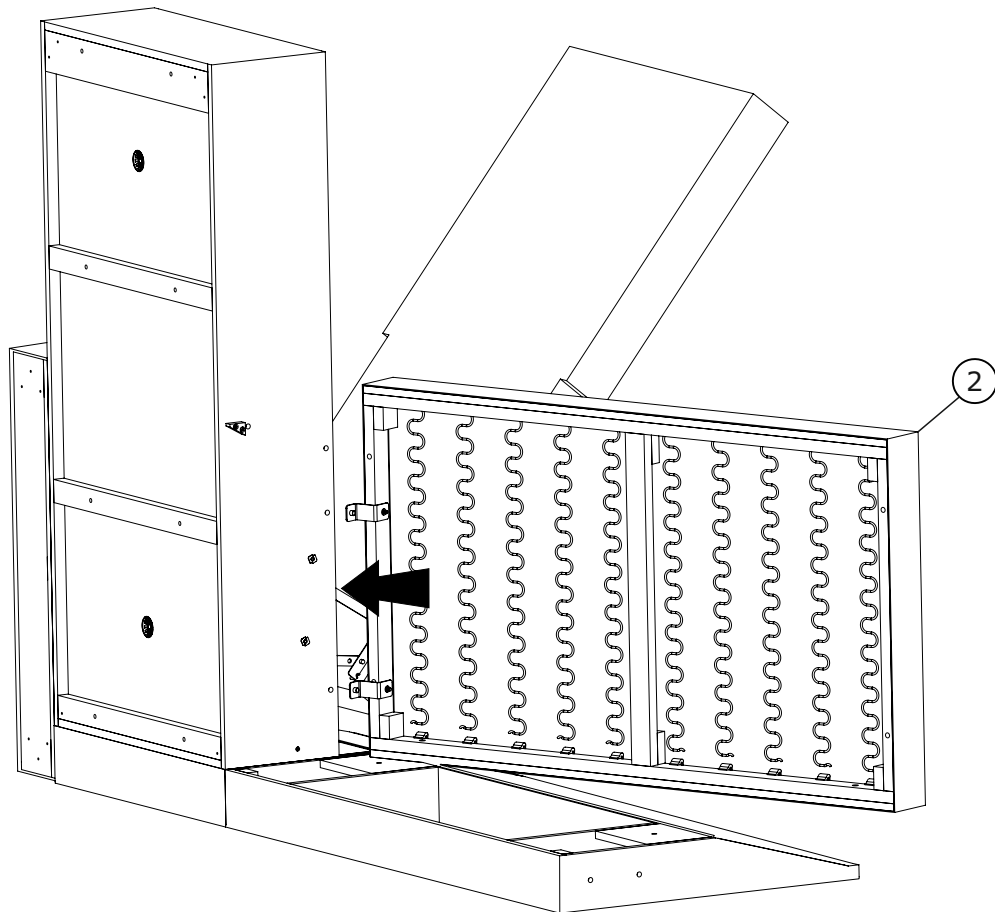

31

U x 2  M6x20 mm	S x 1  4 mm
--	--

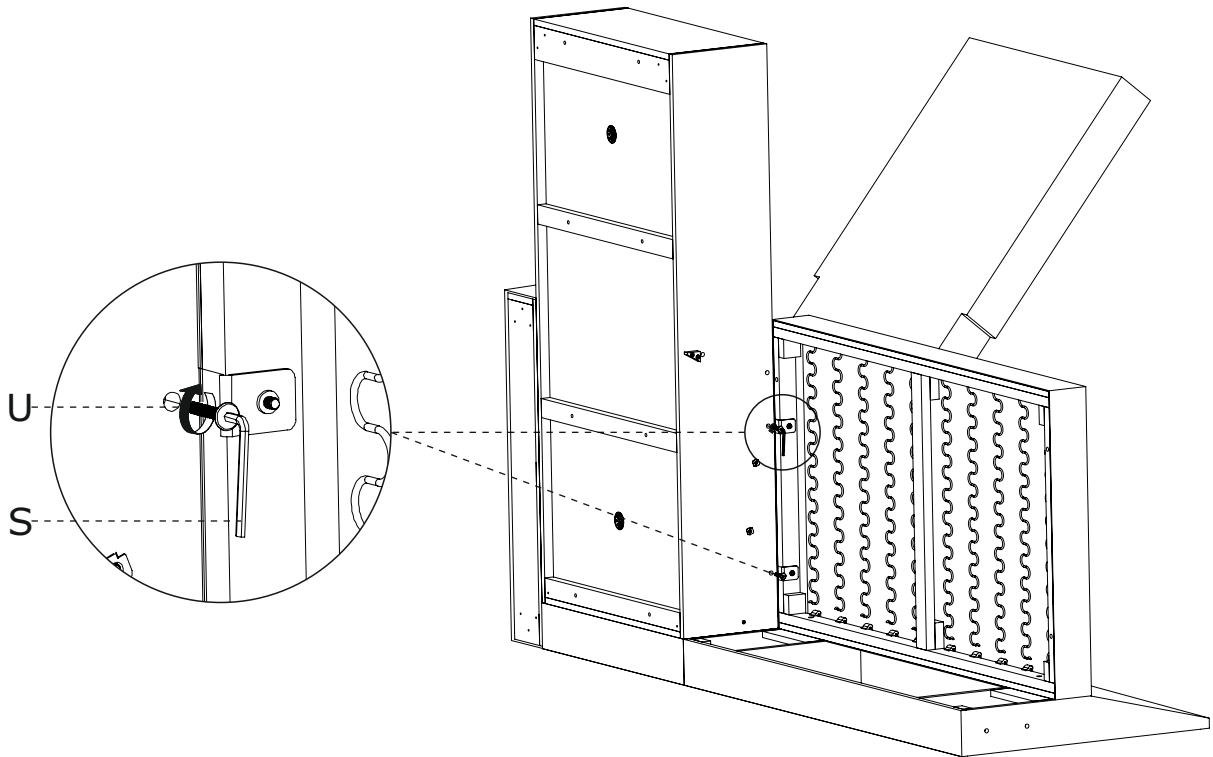

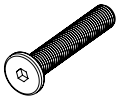
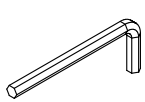

32

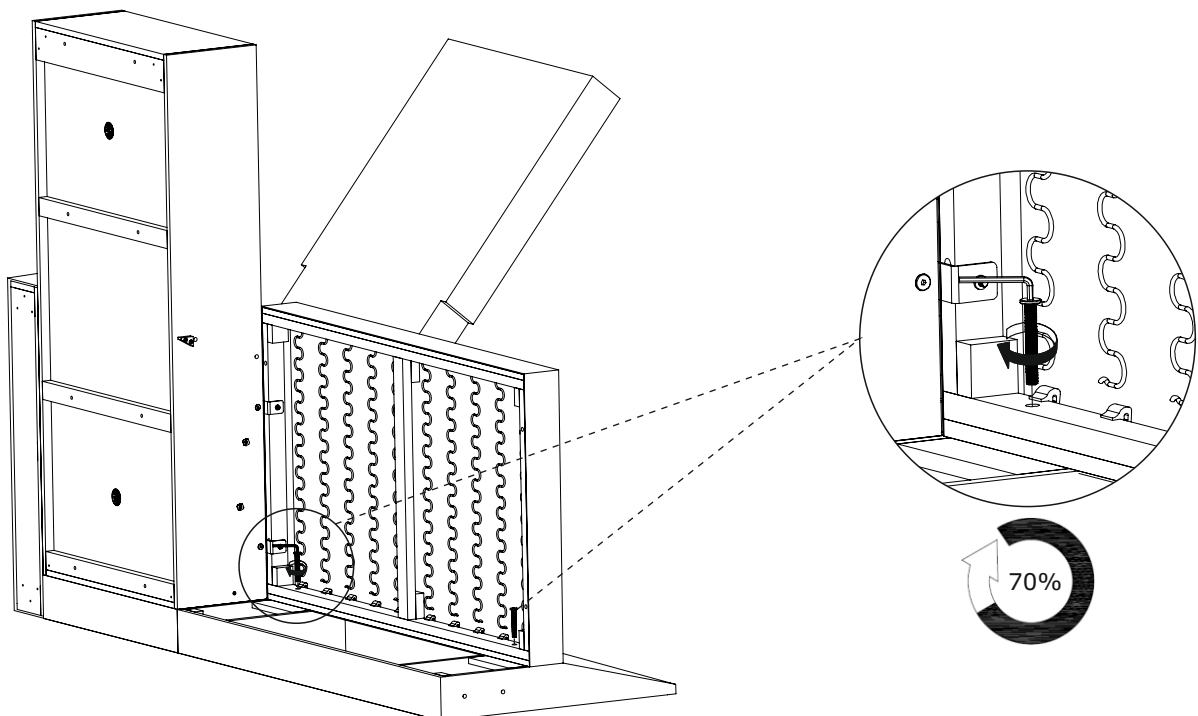
A x 2  M8 x 75 mm	F x 1  5 mm
--	--

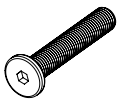
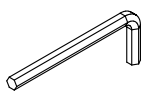

33

A x 2  M8 x 75 mm	F x 1  5 mm	M x 2  Ø40 x 3 mm
--	--	--

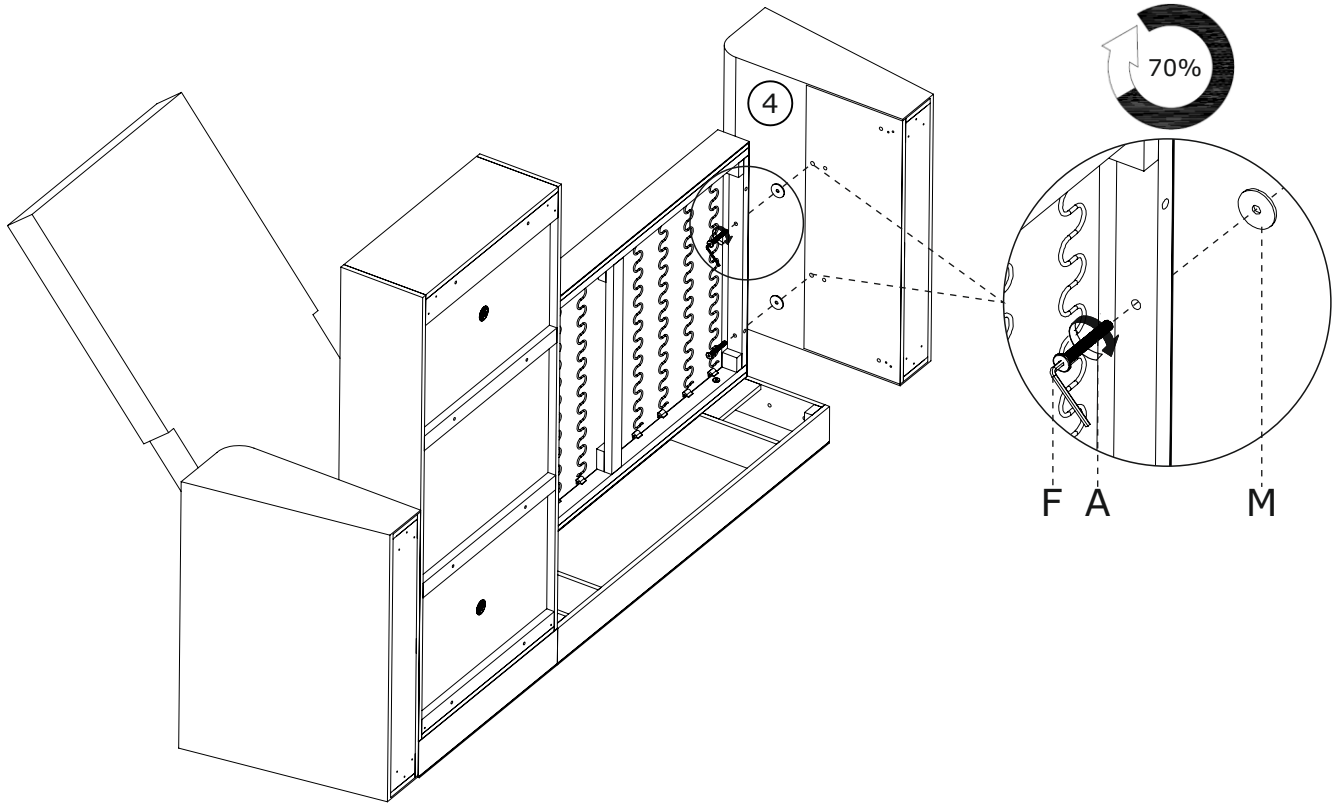

34

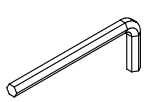
B x 1  M8 x 50 mm	F x 1  5 mm
--	--

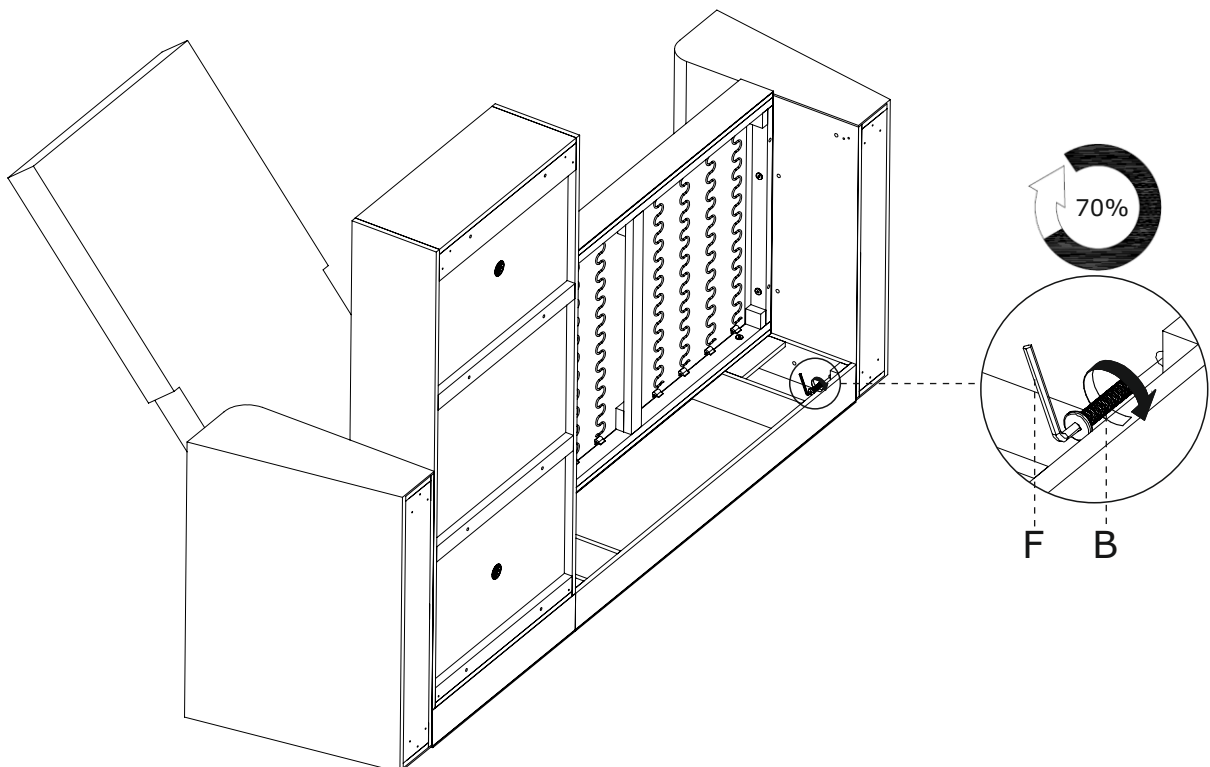

35

<p>K x 2</p>  <p>Ø5 x 35 mm</p>	<p>E x 1</p>  <p>35x24x15 mm</p>	
--	---	---

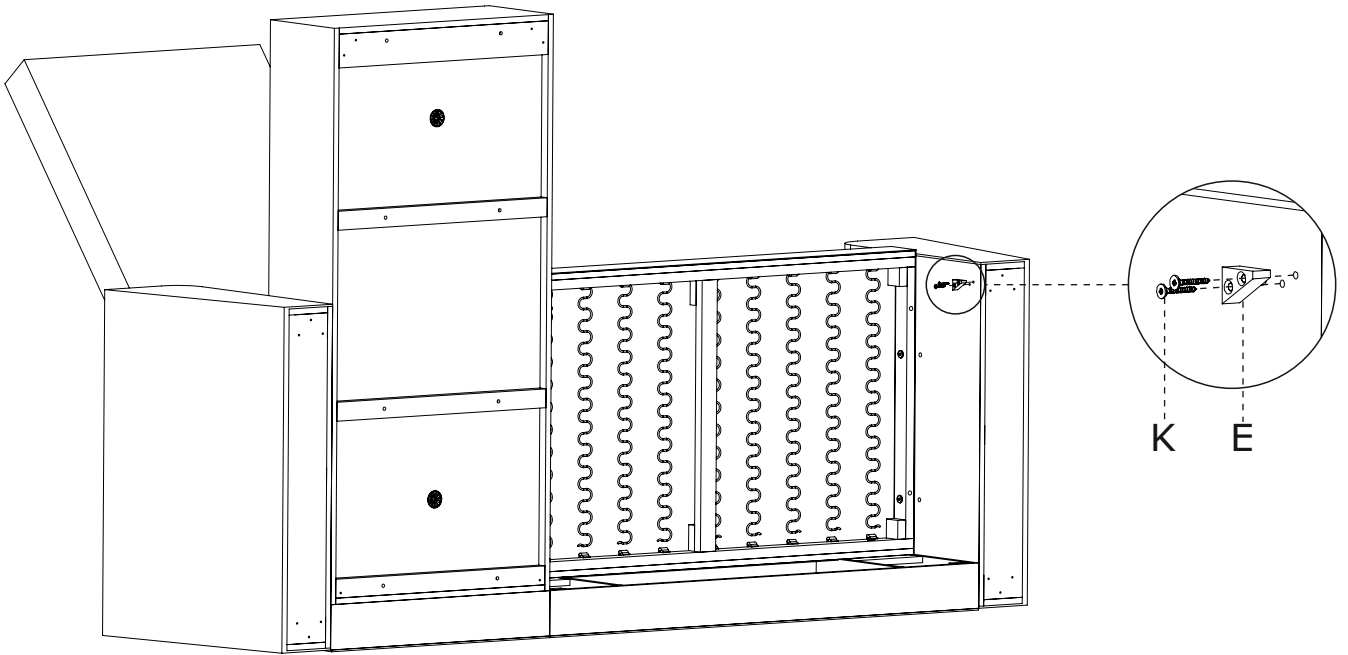

36

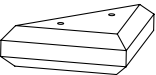
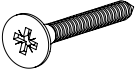
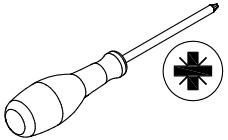
<p>C x 4</p>  <p>Ø50 x 35 mm</p>	<p>J x 4</p>  <p>105x105x35mm</p>	<p>K x 12</p>  <p>Ø5 x 35 mm</p>	
---	--	---	---

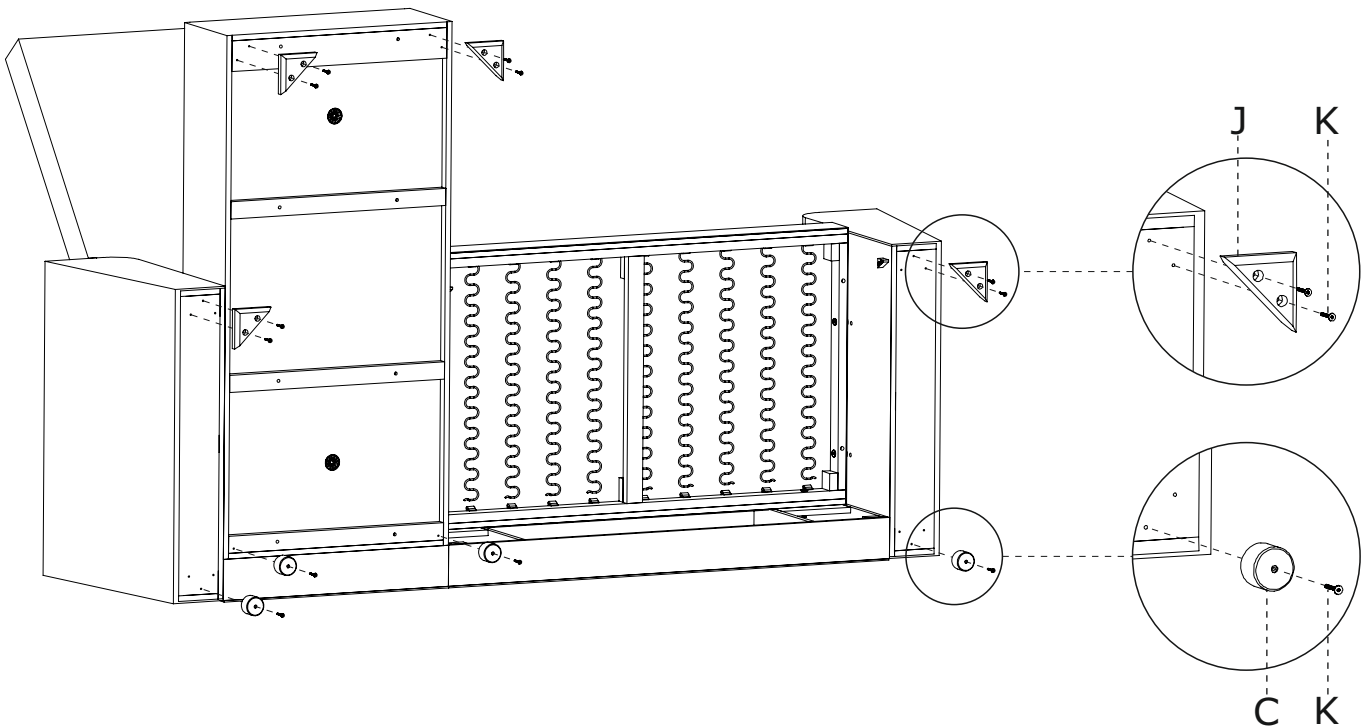

37

L x 4	
	
Ø30 x 2 mm	

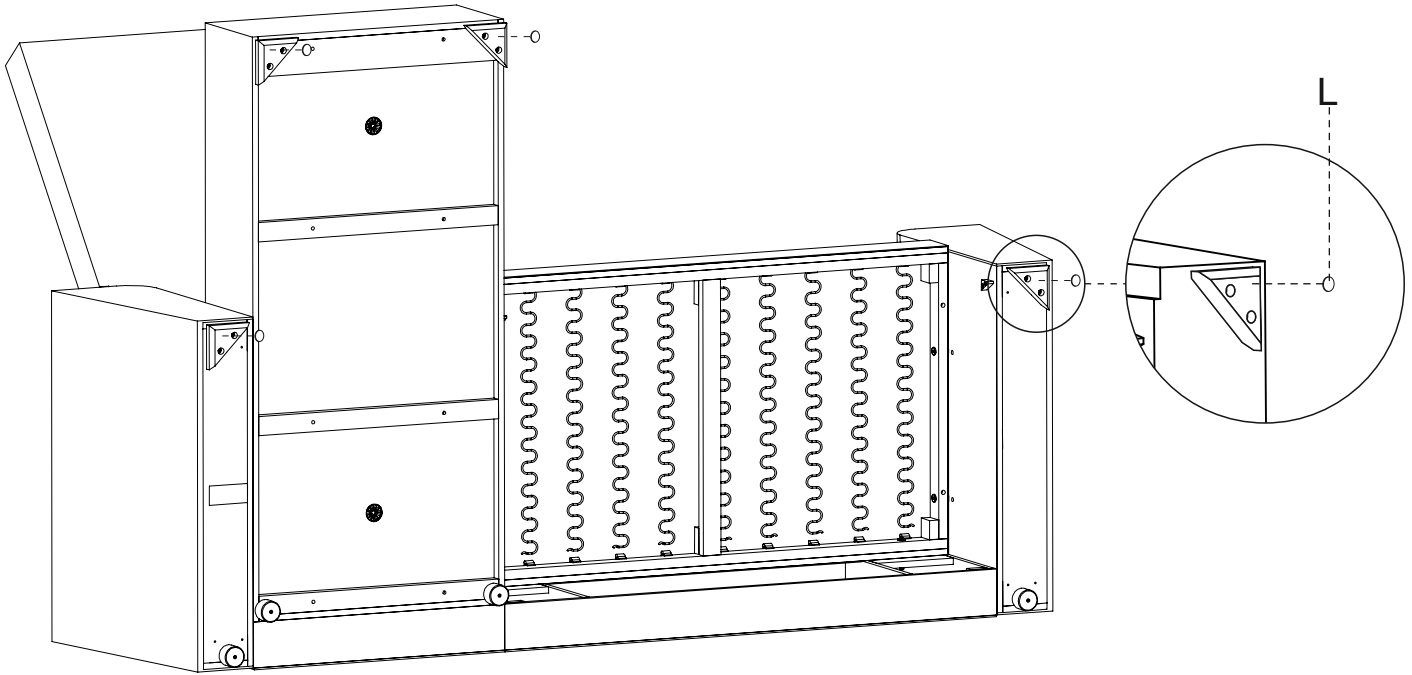

38

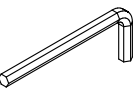
F x 1	
	
5 mm	

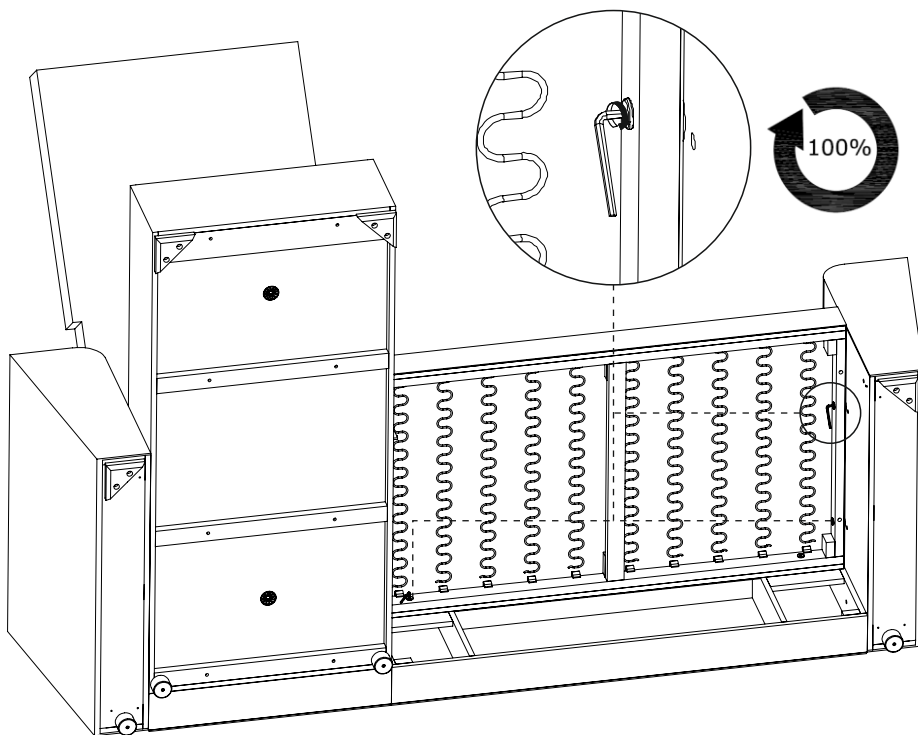

39

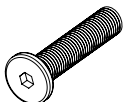
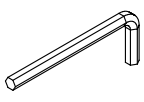
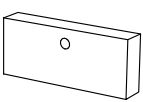
<p>B x 1</p>  <p>M8 x 50 mm</p>	<p>F x 1</p>  <p>5 mm</p>	<p>N x 1</p>  <p>100x46x22 mm</p>
--	--	--

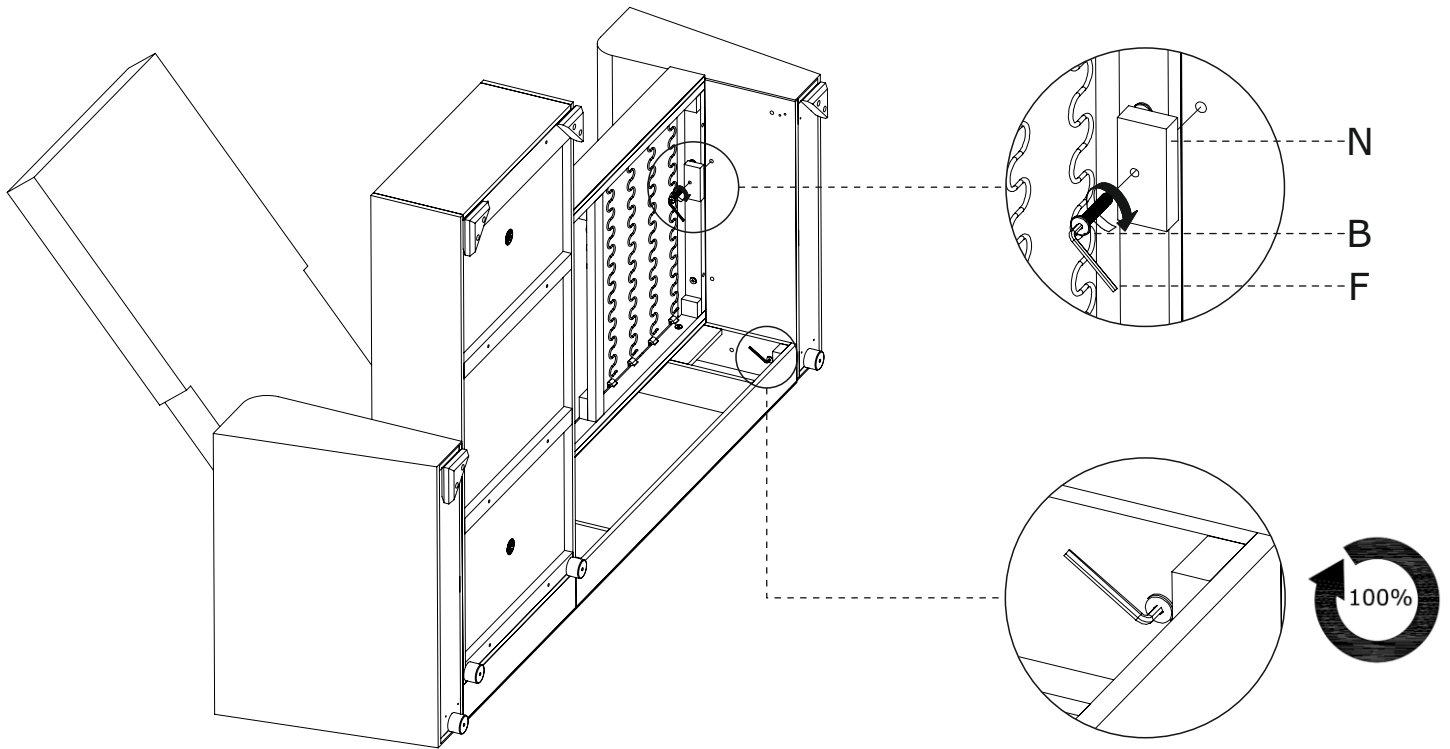

40

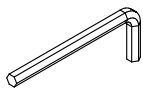
<p>F x 1</p>  <p>5 mm</p>
--

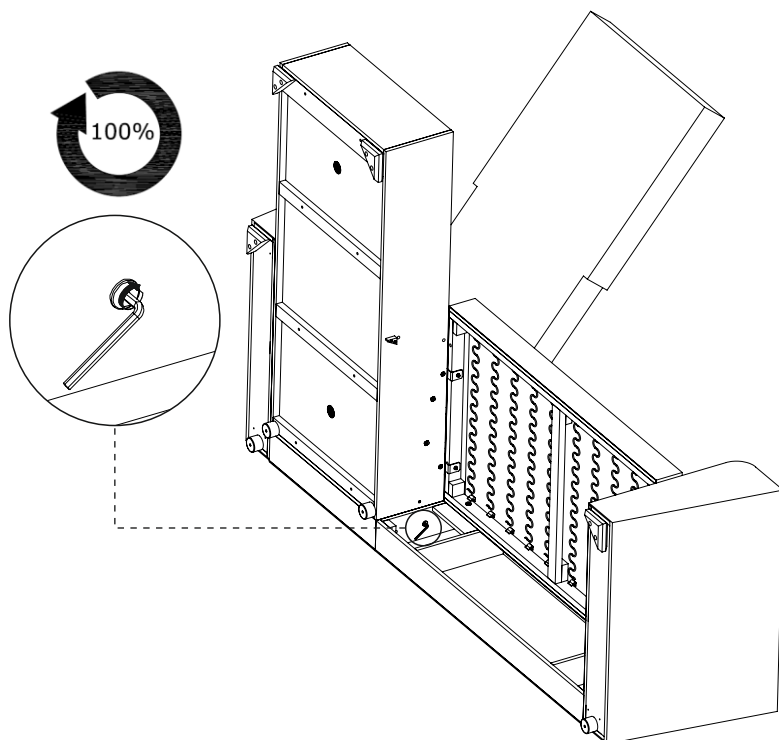

41

<p>G x 4</p>  <p>Ø40 x H-49</p>	<p>H x 8</p>  <p>Ø4 x 35 mm</p>	 
--	--	---

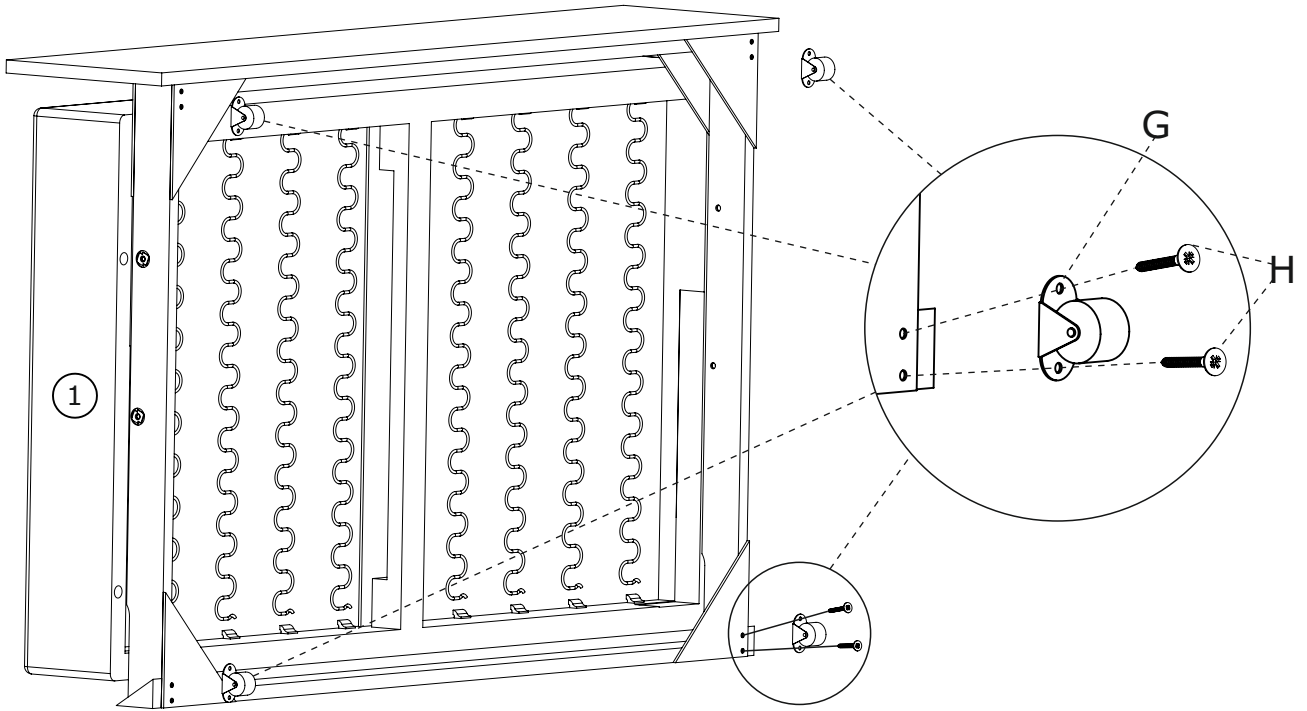

42

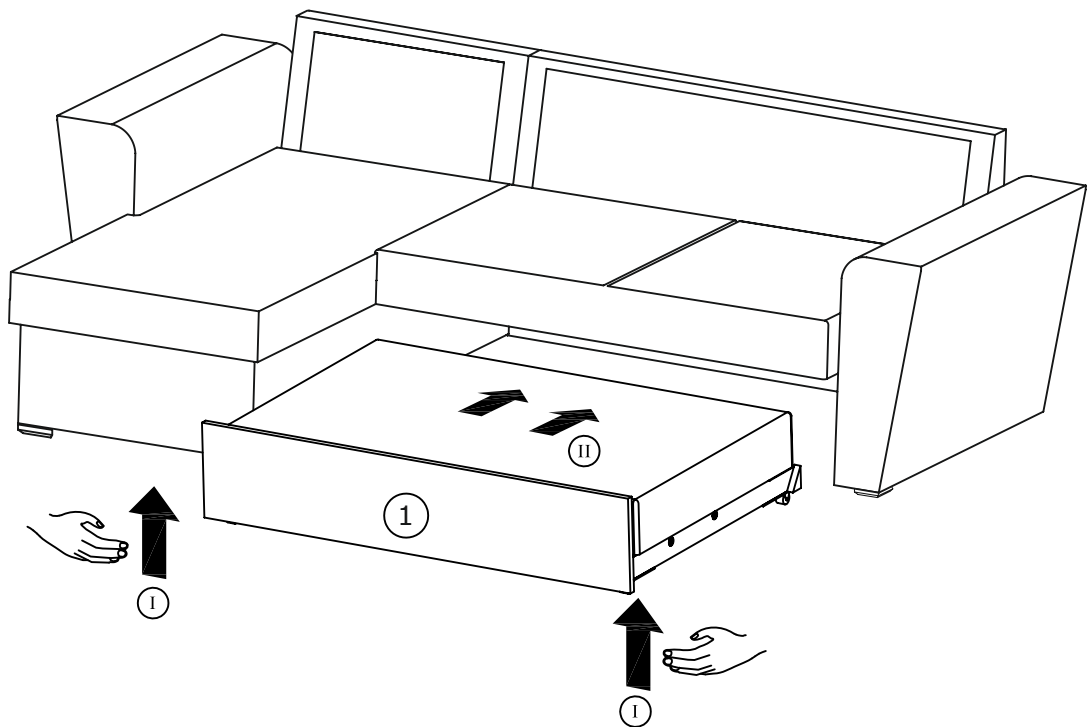

43

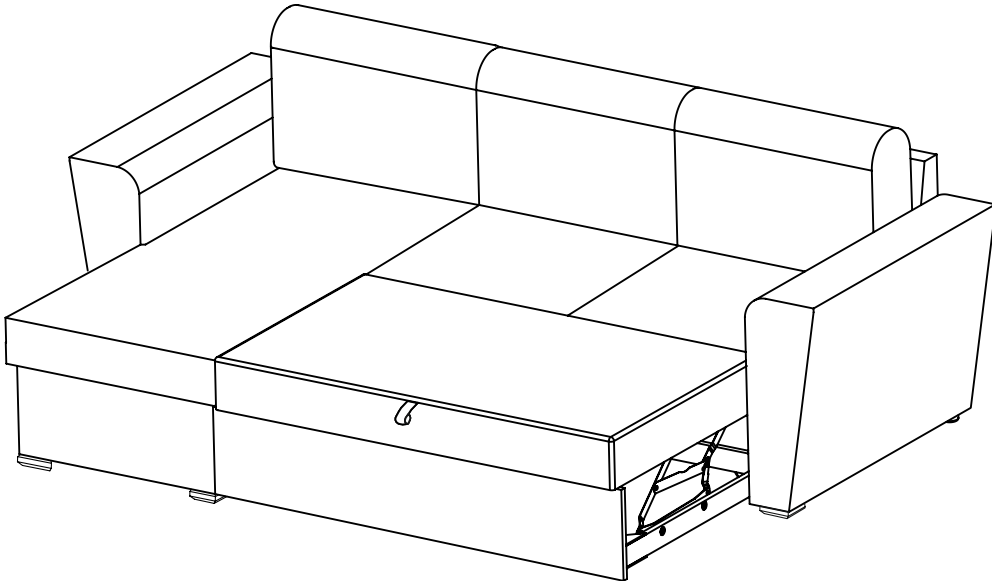
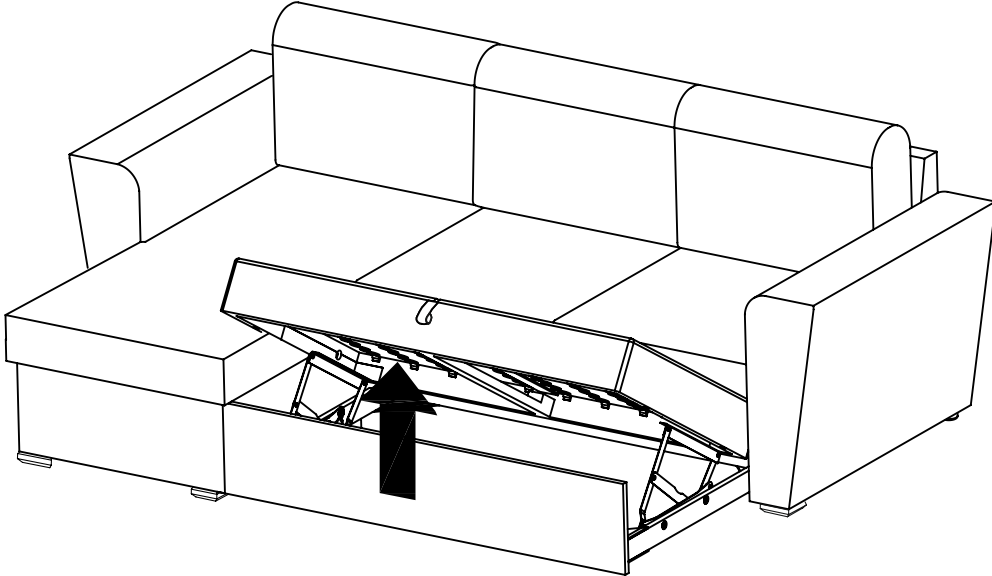
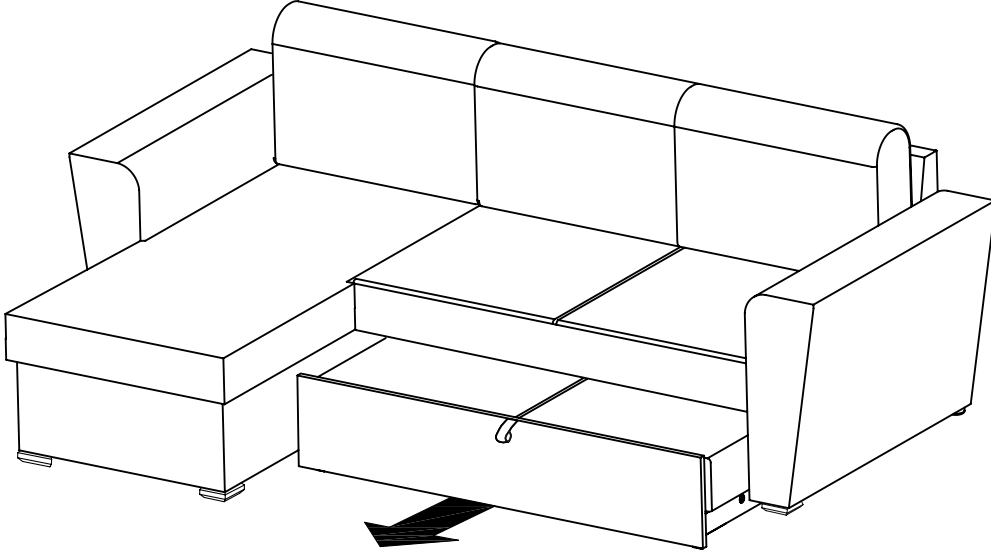

44

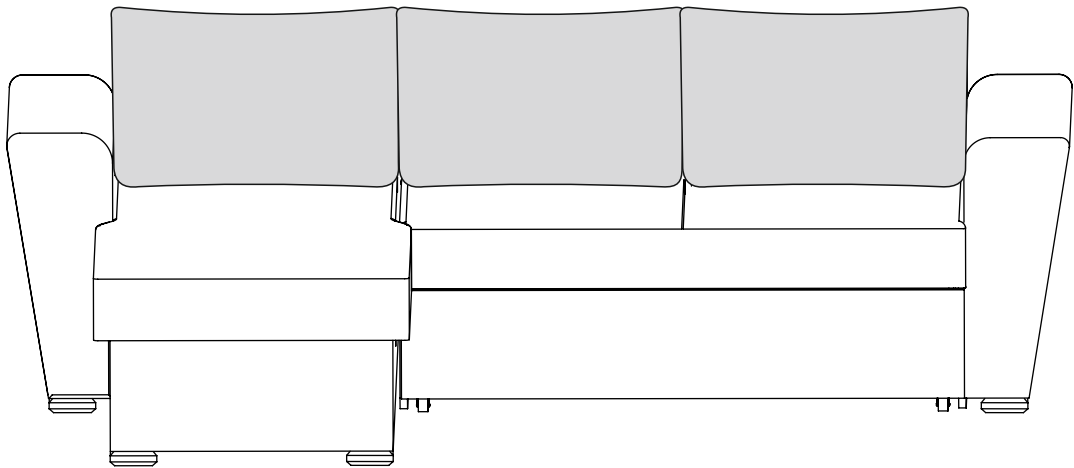
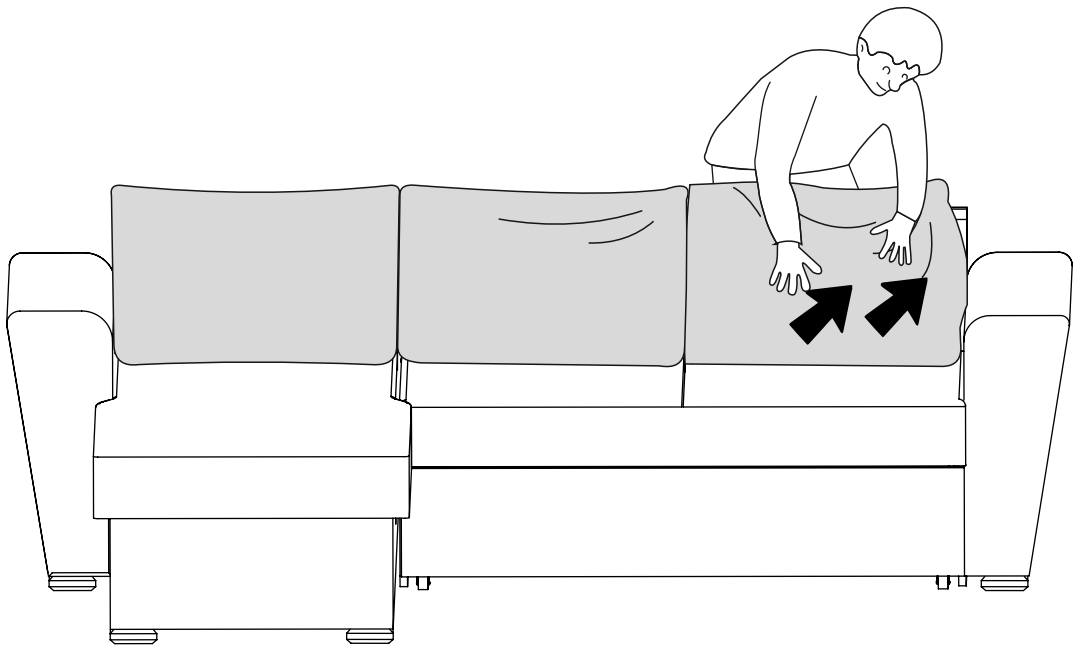
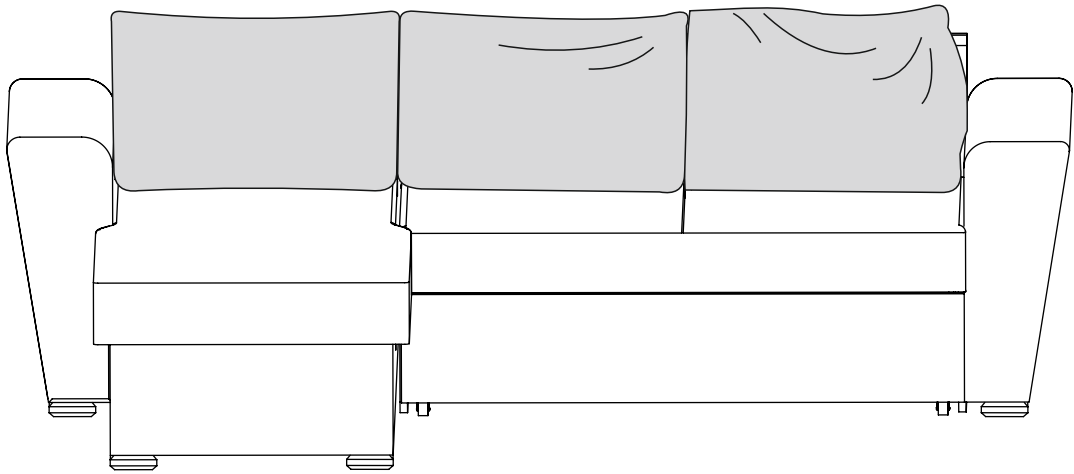

45

